

Handheld Laser Marking Machine User Manual

Applicable model: 20W/30W/50W

(The picture is for reference only, and the machine is subject to the actual product)



Please read the instruction manual carefully before using the product. Please keep this instruction manual properly for your future reference

Glossary

The following terms describe the level of danger caused by improper operations.

take care

If the instructions are not followed for operation, it may damage the product performance and slightly damage the product itself or the affected object.

be careful

If the instructions are not followed for operation, it may damage the product performance and seriously damage the product itself or the affected object.

Attention!

Do not aim the javelin body at people or animals when using it, as it can cause incalculable risks!

warning

If the instructions are not followed for operation, it may damage the product performance and seriously damage the product itself or the affected object, causing uncontrollable accidents.

warning

Please read the entire user manual before using the product and familiarize yourself with its functions before proceeding with the operation. If any harm, product damage, or property loss is caused to oneself or others due to improper operation of this product, our company will not bear any legal responsibility. Do not use components that are not provided or recommended by our company. You must strictly follow our company's instructions for installing and using the product, otherwise you

will not be able to obtain our after-sales service. This guidance document contains instructions for safety, operation, and maintenance. Be sure to carefully read the user manual before assembly, setup, and use.

Product Safety Usage Guidelines

warning

Improper use may result in fire, object, or personal injury. Be sure to follow the following safety guidelines when using the product.

Product Disclaimer

Please carefully read all safety tips, warning messages, terms of use, and disclaimers. Before use, please refer to the terms of use and disclaimer of our product, as well as the yellow warning label on the product. The user assumes full responsibility for all use and operation. Familiar with the relevant regulations in your region. It is your responsibility to understand all relevant regulations and use our products in a compliant manner.

Product Usage:

1. Before using the equipment, pay attention to the following laser label pasting positions and carefully read the instructions.



2. During the use of this product, do not expose your eyes or skin to the laser.



3. During the operation of the product, the performance parameters of the emitted laser are as follows.

characteristic	MFPN-20M-0.7	MFPN-25M-0.6	MFPN-30M-0.7	MFPN-50M-1.1	unit
pulse width	90±10@27kHz	100±20@40kHz	100±20@40kHz	100±10@45kHz	ns
repetitive frequency	27~60	40~60	40~60	45~170	KHZ
Maximum output power	Depending on the purchased model				

4. Note 1- Using controls, adjustments, or execution procedures outside of the provisions of this specification may result in hazardous radiation exposure.

5. The laser radiation level emitted by the provided laser aperture exceeds level 1.

6. It is recommended to wear protective glasses with an optical density of OD3.

7. Strictly keep the product in contact with any liquid, and do not immerse the product in water or get it wet. Remember to use the machine in rain or long-term humid environments, otherwise it may cause internal circuit shorts and cause machine failure; When the battery version is exposed to water or long-term humid environments, it can cause the battery to short-circuit naturally and may even cause an explosion.

8. It is strictly prohibited to use unofficial or designated components. If you need to replace it, please check our official

website for relevant purchase information or contact after-sales service. We are not responsible for any product accidents or malfunctions caused by the use of products not provided by our company.

9. Before installing or unplugging other modules of the machine, please keep the power supply of the machine turned off. Do not plug or unplug other modules or components while the machine is powered on, as this may damage various components.

10. If the ambient temperature is too high (above 60°C), it may cause the battery board to catch fire or even explode. If the ambient temperature is too low (below -20°C), the characteristics of the battery in the battery version product will be severely reduced, and the LCD display may also be unable to display, which cannot meet the normal usage requirements. After the design is restored to the normal operating temperature range, it can be used normally.

11. It is prohibited to use the machine in strong static or magnetic field environments, as abnormal operation may occur. Otherwise, some functions of the machine may malfunction, leading to serious machine malfunctions.

12. It is prohibited to disassemble or puncture sharp objects in any way. Otherwise, the machine's functions may malfunction, leading to serious malfunctions.

13. If the machine encounters a strong fall or is hit by external forces, it may cause functional abnormalities of the machine,

leading to malfunctions. There is a risk of battery rupture in the battery version, which can cause serious consequences.

14. If the product accidentally falls into the water during use, place it in a safe and open area, and stay away from the product until it completely dries. Dried products should not be reused and should be properly disposed of according to the disposal methods outlined in this article. If the product catches fire, it is recommended to use fire extinguishing equipment in the following order: water or mist, sand, fire blanket, dry powder fire extinguisher, carbon dioxide fire extinguisher.

15. Do not place the product in a microwave or pressure vessel.

16. It is prohibited to use wires or other metal objects to penetrate the product casing under abnormal conditions, which may lead to serious consequences such as short circuits and uncontrollable risks.

17. Do not hit the machine. Do not place heavy objects on the machine.

18. If there are stains on the touch screen of the product, please use a professional capacitor screen cleaner to wipe it off.

19. If there is dust on the ventilation hole of the product, please use a brush to clean it. (Severe blockage, please contact after-sales personnel)

20. It is recommended to use a moisture-proof bag together in damp environments (such as by the seaside or water edge) to avoid water intrusion and soaking. If water is found inside

the product, it should not be used or turned on again. For maintenance, please contact after-sales service.

Product charging:

1. The product must be charged using our official designated charging equipment. We will not be responsible for any consequences caused by using charging equipment that is not officially designated by our company.
2. When charging, please place the machine on a ground with no flammable or combustible materials around it. Please be present during product charging to prevent accidents.
3. Avoid continuous full load discharge. The product battery may be in a high-temperature state. Please wait for the machine to cool down to room temperature before proceeding.

Product storage and transportation:

1. Please store the machine out of reach of children. If children accidentally come into contact and open the machine, improper operation can cause serious consequences.
2. If the machine prompts a severe low battery after use, please charge it before storing it. Otherwise, prolonged storage may cause damage to the battery inside the product. If the machine battery is severely low and idle for a long time, the battery will enter deep sleep mode. If the battery needs to be awakened from deep sleep, the machine needs to be charged.
3. Do not allow the machine to approach heat sources, such as in a hot car, a fire source, or heating equipment.
4. The environment for storing the machine should be kept dry. Do not leave the machine in a damp or potentially leaking area

for an extended period of time.

5. It is prohibited to store or transport the machine together with metal objects. If you need to use express delivery or logistics to transport batteries, please reduce the battery level to less than 30%.

Abandonment of product batteries:

1. Be sure to completely discharge the machine battery before placing it in the designated battery recycling bin. Batteries are hazardous chemicals and are strictly prohibited from being disposed of in ordinary garbage bins. Please comply with local laws and regulations on battery recycling and disposal when disposing of batteries.

2. The discharged battery has been damaged, please dispose of it as waste.

Product maintenance:

1. According to actual usage, the machine conducts necessary dust removal on the heat dissipation pores, which can effectively maintain a more efficient heat dissipation efficiency of the machine.

2. The usage and storage environment temperature of the battery is -20°C to 45°C , and the optimal usage and storage environment temperature is 20°C to 25°C .

3. If the machine is idle for a long time, it will affect the internal battery performance of the machine.

4. Please charge and discharge the machine battery every 1 month, that is, first discharge the battery to 30%, and then charge it to 85% to maintain battery performance.

Boarding precautions:

Unable to carry this machine on board.

Congratulations!

Congratulations on becoming a handheld laser marking machine user of our company! This brief manual will be helpful to you. Please take some time to read the manual and follow the instructions on the manual to use this product and master the usage method!

List

1. Home	1
1.1. Login	1
1.2. System status bar	1
1.3. Edit bar	4
1.3.1. Add words	5
1.3.1.1. Add fixed text	6
1.3.1.2. Add serial number	8
1.3.1.3. Add the date / time	12
1.3.1.4. File read	15
1.3.1.5. Add Plan	19
1.3.1.6. Add external data	21
1.3.1.7. Add random code	22
1.3.2. Draw	23
1.3.2.1. Add Dot	23
1.3.2.2. Add Line	24
1.3.2.3. Add straight line	25
1.3.2.4. Add tear line	26
1.3.2.5. Add a circle	27
1.3.2.6. Add rectangle	27
1.3.2.7. Add graph	28
1.3.2.8. Add barcode	29
1.3.2.9. Add QR code	36
1.3.2.10. Add delayer	49
1.3.2.11. Output port	51
1.3.3. New	51

1.3.3.1. File open	51
1.3.3.2. Save	52
1.3.3.3. Save as	52
1.3.3.4. Undo	53
1.3.3.5. Redo	53
1.3.3.6. Copy	53
1.3.3.7. Delete	53
1.3.3.8. Tool	53
1.3.3.9. Object	56
1.3.3.10. Arc text	59
1.3.3.11. Fill	61
1.3.3.12. Array	63
1.3.3.13. Parameters	65
1.3.3.14. Dimensions and coordinates	65
1.3.3.15. File management	66
1.4. System toolbar	67
1.5. Keyboard introduction	67
2. Production line setting	68
2.1. Static spray code setting	68
2.1.1. Jog mode	68
2.1.2. Sensor / Foot mode	69
2.2. Flight marking setting	71
2.2.1. Normal mode	77
2.2.2. Pipeline mode	78

2.2.3. Continuous mode	79
3. Setting	80
3.1. Marking parameters	80
3.2. Area	86
3.2.1. The vibration mirror calibration	86
3.2.2. Forced light	90
3.2.3. Red light guide calibration	90
3.3. Laser	92
3.4. User Rights	94
3.5. Font management	96
3.6. System settings	97
3.7. IO settings	106
3.8. Comm settings	109
3.9. System info	109
3.9.1. Update	110
3.9.2 Registered	113
4. Equipment parameters	114
5. Packaging content	117

1. Home

The main interface is shown in Figure 1-1:

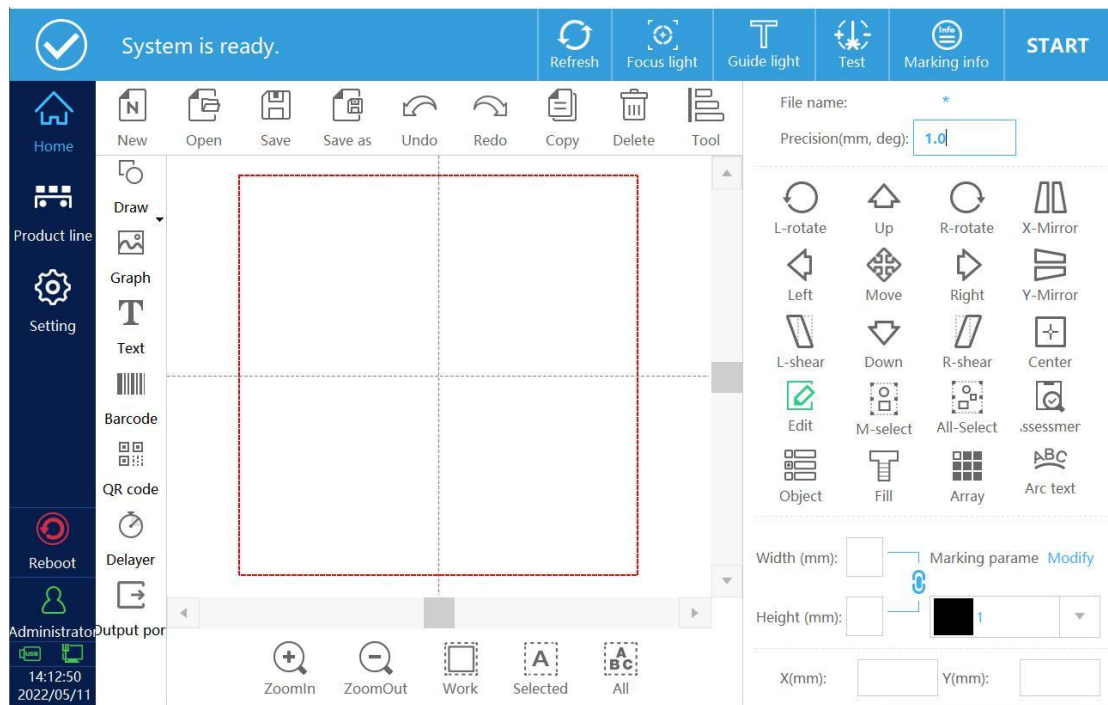

Figure 1-1

1.1. Login

Click the login button, a password input interface pops up, login password: 123 (administrator, you can log in to the system with different permissions)

1.2. System status bar

As shown in Figure 1-2



Figure 1-2

System status prompt: Prompt that the coding system is ready, marking, or some error alarm information, etc.

Refresh: During the flight marking process, the information can be updated online. There are two situations for online update.

One is to update the marking after performing the system cache

twice, that is, after clicking online update, the system will perform another marking and update on the content once. The modified content is marked, a real-time update, that is, after clicking online update, the system's next marking is the modified content (for high-speed production lines, real-time update will cause missed marking)

Focus light: This function can be used when a red light focusing red light tube is connected to the system, that is, two red lights are connected.

Guide light: The red light guides the light and previews the data marking area.

Test: Test the marking time of the currently selected data, the marking time can be seen in the status bar after marking.

Marking info: Click the button, the pop-up interface as shown in Figure 1-3.

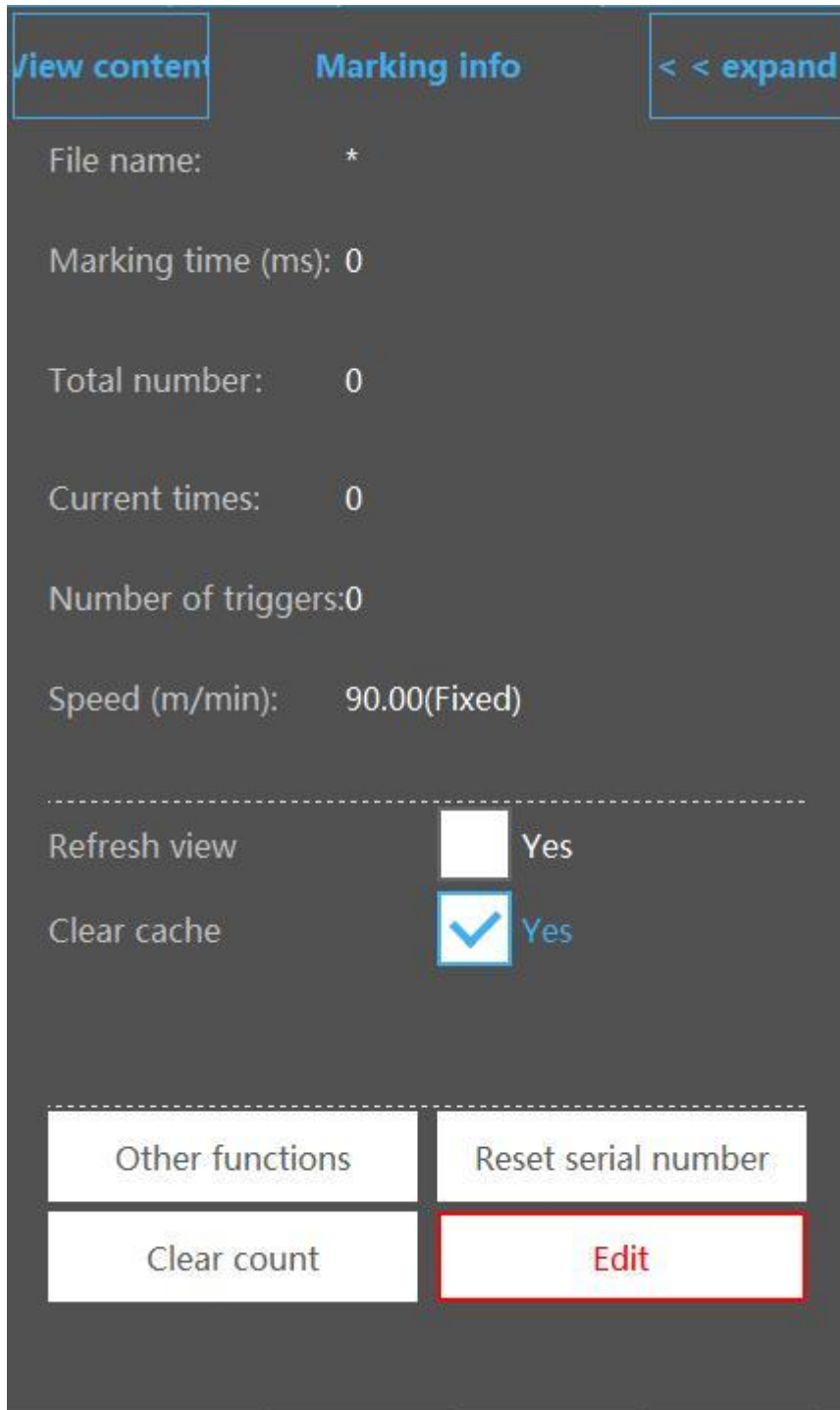

Figure 1-3

View content:View the current marking content.

File name:Display the file currently being marked.

Marking time(S):Current file marking time.

Current times:Count the number of markings after clicking start coding.

Speed(m/min):The current encoder obtains the real-time speed of the pipeline or the simulated speed set by the system.

Refresh view:During the marking process, the interface content display is refreshed in real time.

Clear cache:When using the online update function, whether to clear the previous state of the marked content in real time.

When it is not checked, the system will update the marking after 2 caches. The system will mark the content twice and update the modified content for marking. When checked, it will be updated in real time, that is, after clicking online update, The next marking of the system is the content after modification(for high-speed production lines,real-time update will cause missed printing)

Clear alarm:Clear alarm information.

Reset serial number:The serial number can be reset without stopping production.

Clear count:Clear current or total times.

Edit:Online editing function, during the marking process, click to return to editing, after the data is modified, click the online update function.

 Start/pause marking button

1.3. Edit bar



Precision:Up, down, left or right, or the distance or angle traveled by each point of the rotary button (unit: mm/deg).

Add object:Add materials that need to be marked, including text, points, lines,circles, rectangles, barcodes, QR codes, graphics, delayer and output ports.

1.3.1. Add words

Click the text button, Enter the content editing interface, as shown in Figure 2-1.

Move up: adjust the data order, and move the data forward

Move down: adjust the data order and move back

Edit: Edit fixed text, serial number, date and time, file read, shift code, external data, or random code

Delete: Delete the added content

Line change: the branch adds information

Management: Manage the variables

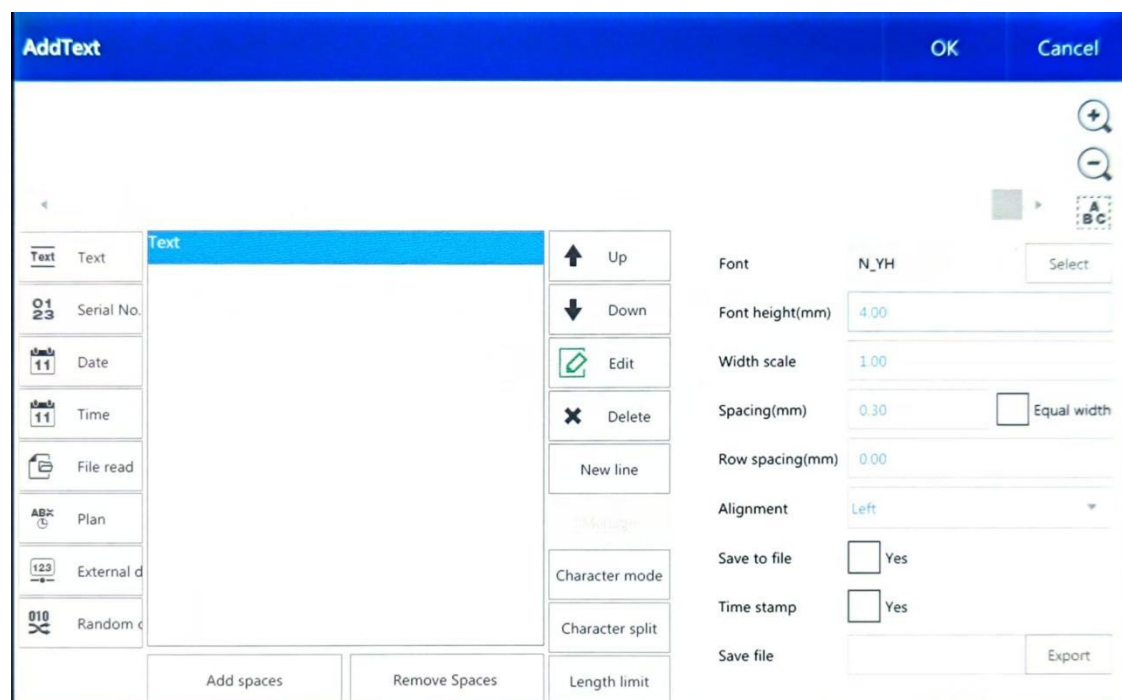

Figure 2-1

1.3.1.1. Add fixed text

After entering the content editing interface, the system will automatically produce a fixed text of empty text, click Edit, pop up the text box, click the blank area, pop up the keyboard, if you need to add a new fixed text, click the fixed text button to add fixed text with the default content is TEXT.

Edit fixed text

Select the fixed text TEXT, as shown in Figure 2-2, click the edit button, enter the editing interface, click the content box, and pop up the keyboard, as shown in Figure 2-3.

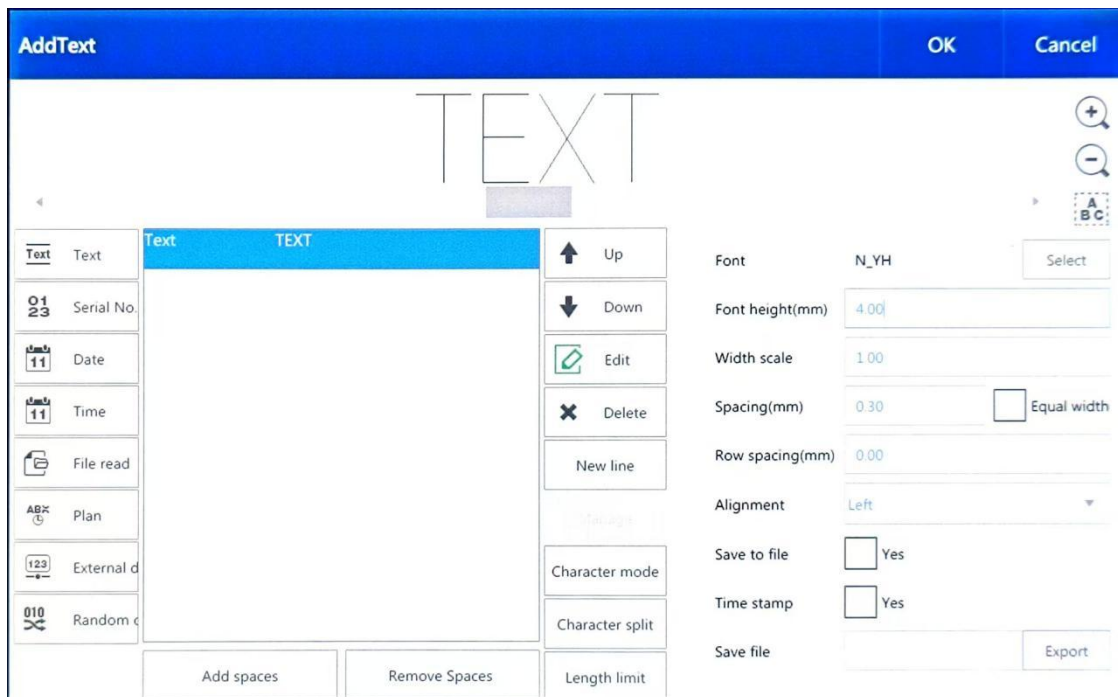

Figure 2-2

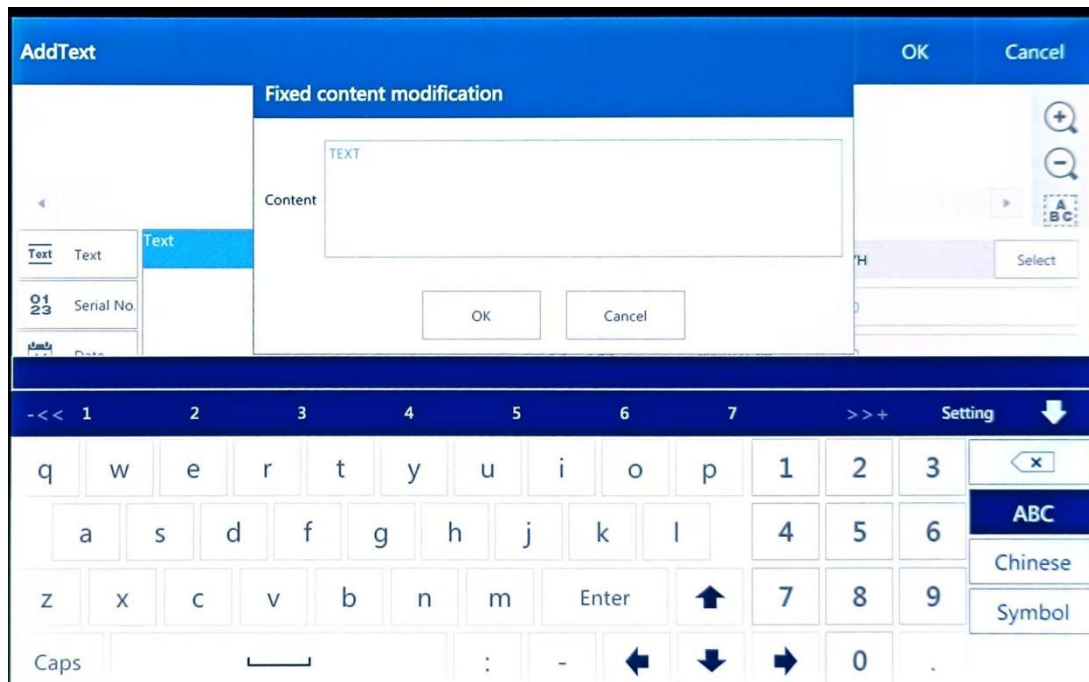

Figure 2-3

Font: Select text font, optional dot matrix font, single-line font or double-line font, as shown in Figure 2-4.

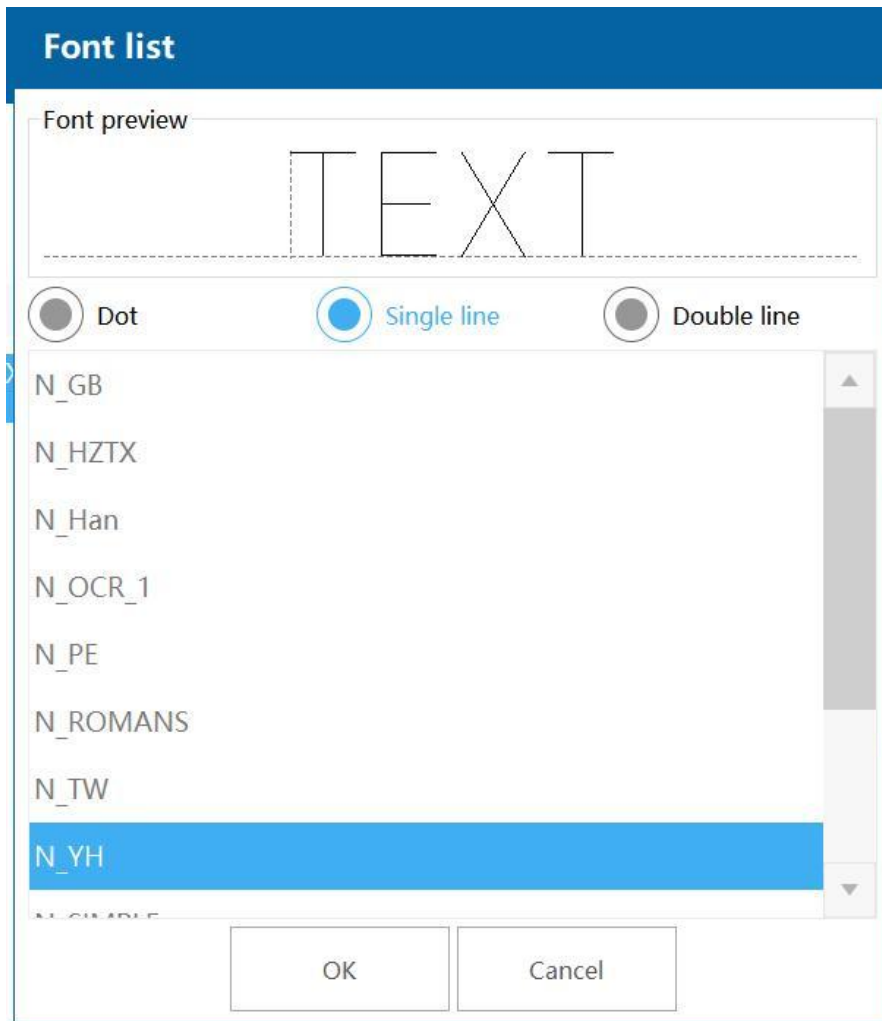

Figure 2-4

Word height: Font height

Word width factor: the default value is 1, change the font width

Spacing: the distance between the characters

Line spacing: the distance between each row and each row in the same text

Alignment mode: the alignment mode between multiple lines in the same book

Save to file, time stamp, save file: record function, record usage.

1.3.1.2. Add serial number

Click on the serial number button, Add a serial number with default content 0000, as shown in Figure 2-5.

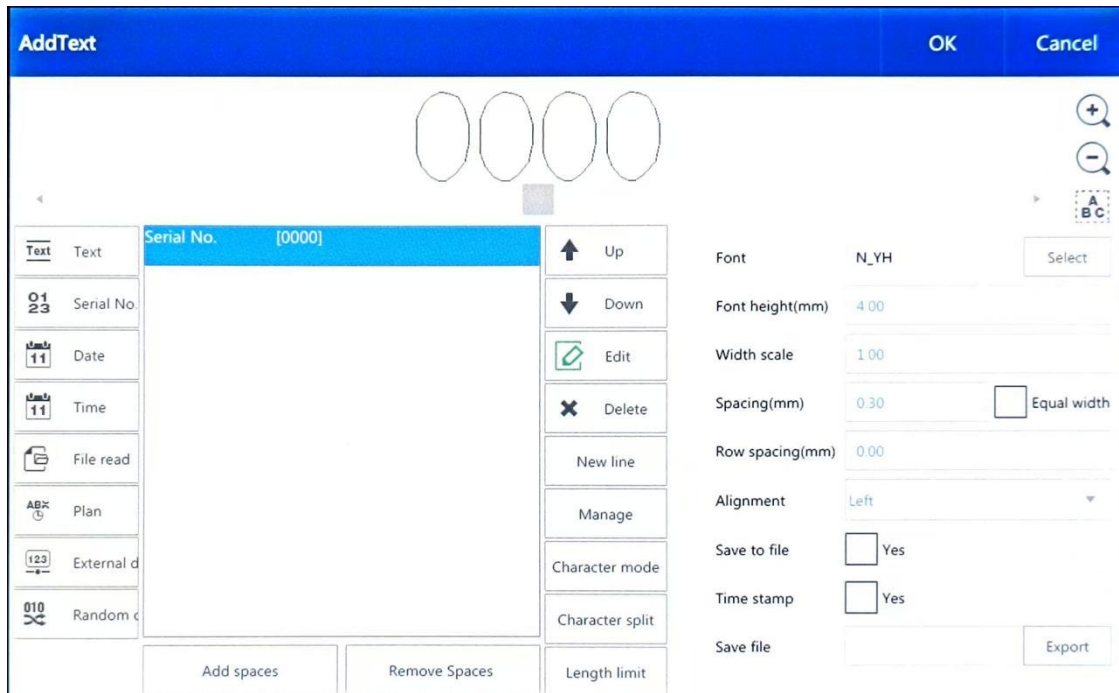

Figure 2-5

Edit the serial number

Select the serial number and click the edit button , Pop up serial number modification interface, as shown in Figure 2-6.

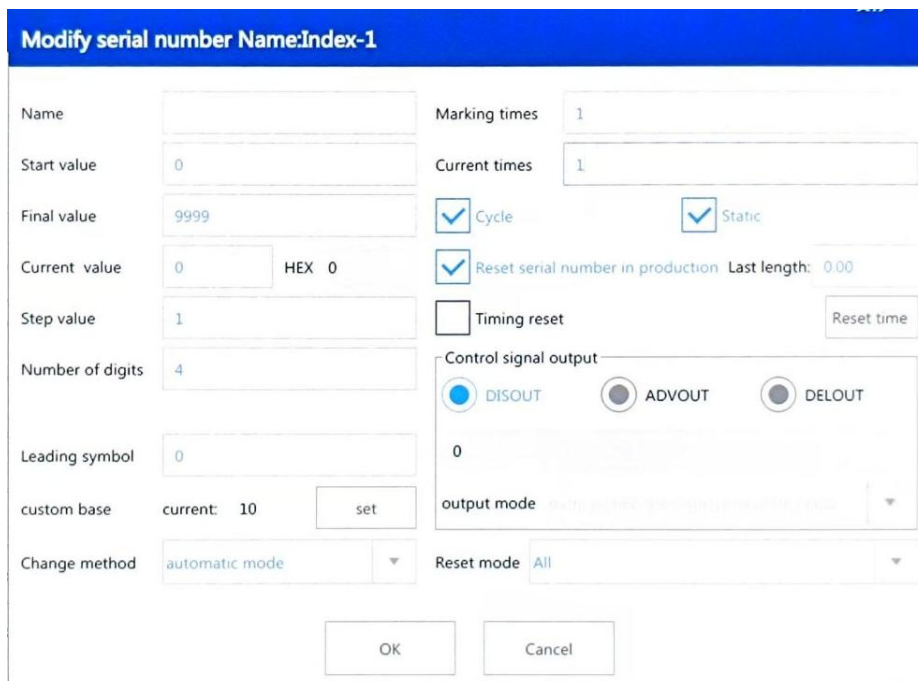

Figure 2-6

Start value	Starting value	Final value	End value
Current value	The serial number that is currently being marked	Step value	Each mark cumulative value
Number of digits	Number of characters	Leading symbol	Character expression symbol
Marking times	Repeat repetition of single serial number	Current times	Repeated serial number has been marked and engraved for several times
Cycle	Whether the serial number is marked in circulation	Reset serial number in production	After checking the box, reset the serial number function to take effect

Name: Current serial number name (blank)
Control signal output: serial number signal output
ADVOUT: advance output with several serial numbers
DELOUT: when the end number set is marked, then delay the distance output, unit mm, the value cannot be set too much, otherwise the alarm will occur

Output mode: output at the end of the serial number or output at the end of the code number.

Output at the end number: output a low level signal when the end value is set.

Output at the end of the spray number: each serial number is set, and a low level signal is output when the set number of times is finished.

Reset mode: you can reset the serial number to the starting value or reset the number of spray times.

Custom base: click set to enter the interface, as shown in the figure, set 20 system, that is, when the serial number is marked to 009, then mark 00A, 00B, 00C... until 00J and then continue to mark 010. Quick format switch, can quickly switch the data format, such as switch to ABC mode, that is, the serial number is expressed as: 00A, 00B, 00C...

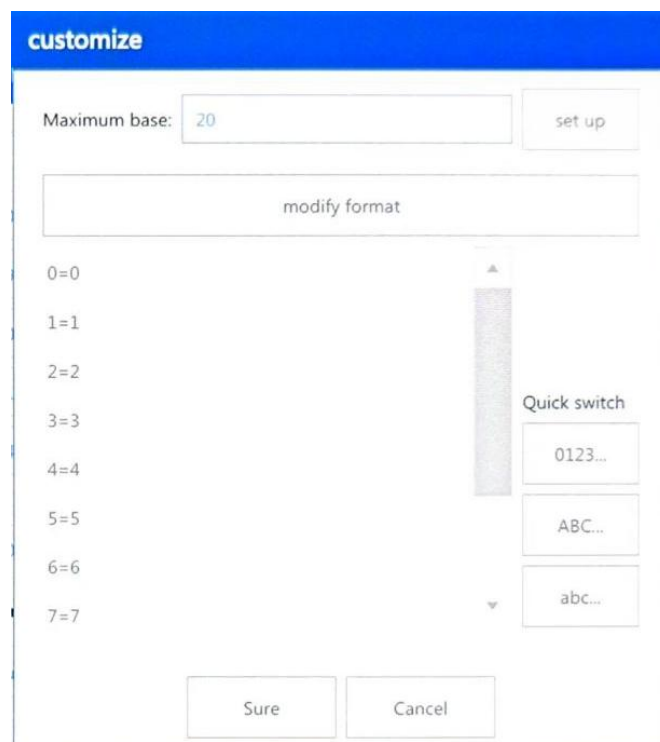

Change method: automatic mode and manual way.

Automatic mode: the serial number will automatically switch to the next position;

Manual way: switch to the next position through external IO input.

Timing reset: Set the reset time point, as shown in the figure, that is, the serial number is regularly reset at 14:22:14 during the code printing process.

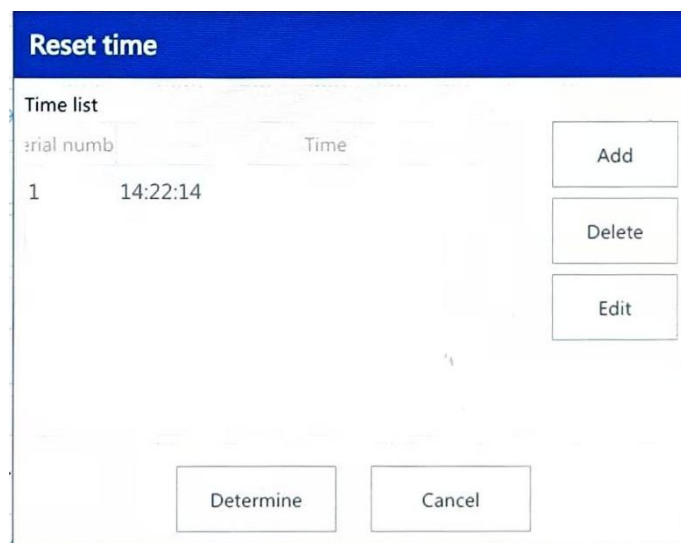

1.3.1.3. Add the date / time

Click the date / time button, and the added date / time is the system date / time, as shown in Figure 2-7.

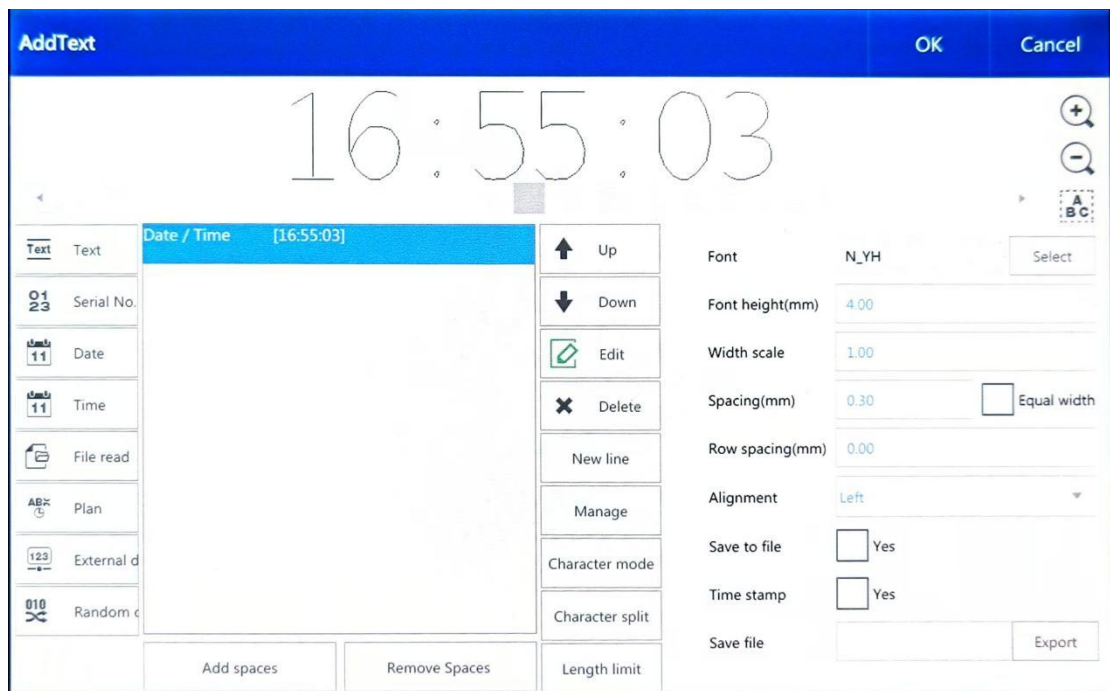
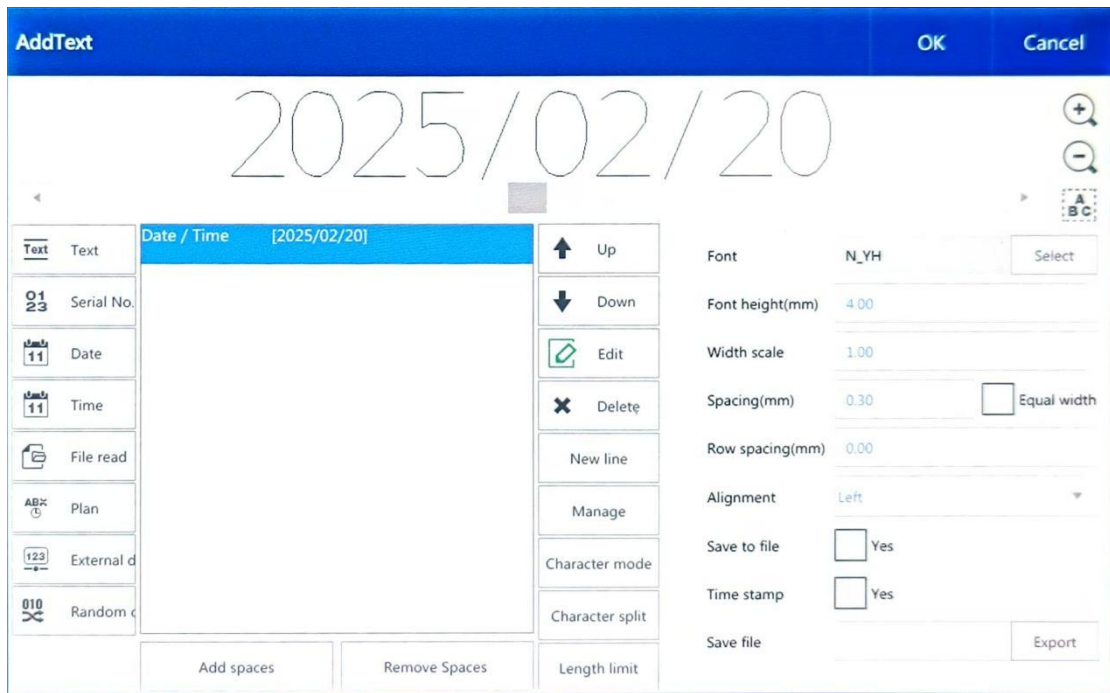

Figure 2-7

Edit the date / time

Select the date / time and click the Edit button, Pop up the time / date modification interface as shown in Figure 2-8.

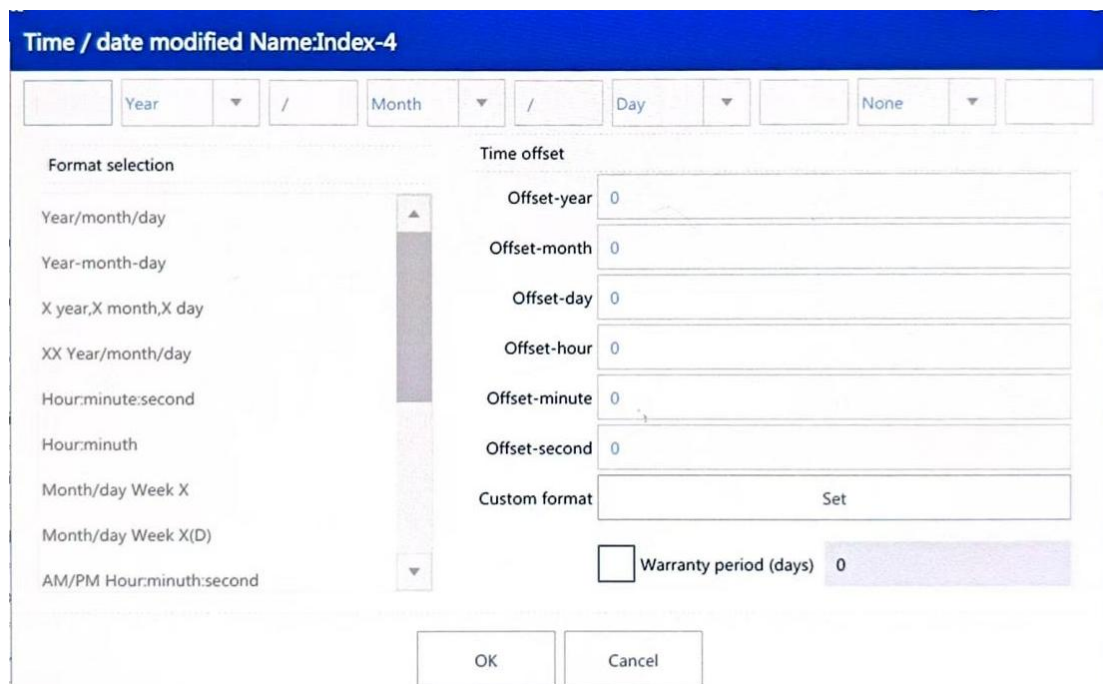

Figure 2-8

Select the format: there is its own time and date format in the system, which you can directly choose to use

Modify the format: modify the time / date format, you can modify the separator sign, and the order of year,month,day, etc.



Time offset: you can change the year, month, day, hour, minutes, seconds, that is, on the basis of the current time to increase or reduce the set value, add the value after the day to 1, reduce the value after the day to -1. The rest is the same.

Custom format: the representation of customized time variable, as shown in the figure, click Enable customization, select the following year, click to modify the format.

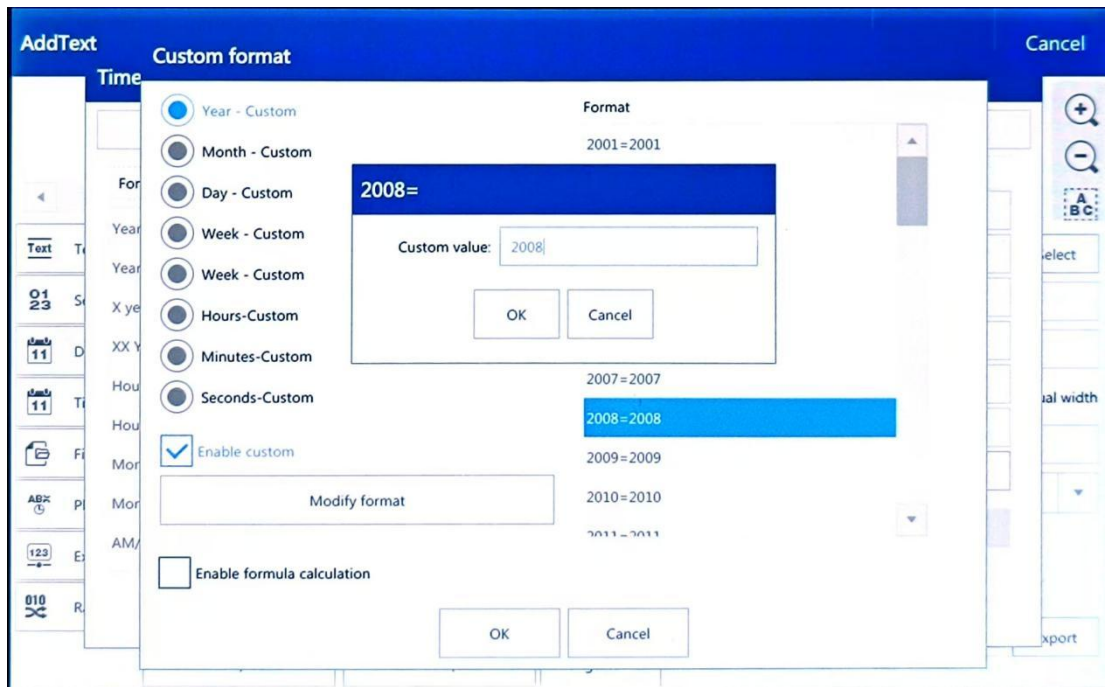

Warranty period (days): During this time period, when the date / time is edited, the system will default to set the custom format.

1.3.1.4. File read

Click on the file read button, Select the text file or the excel file, and add the blank file, as shown in Figure Figure 2-9.

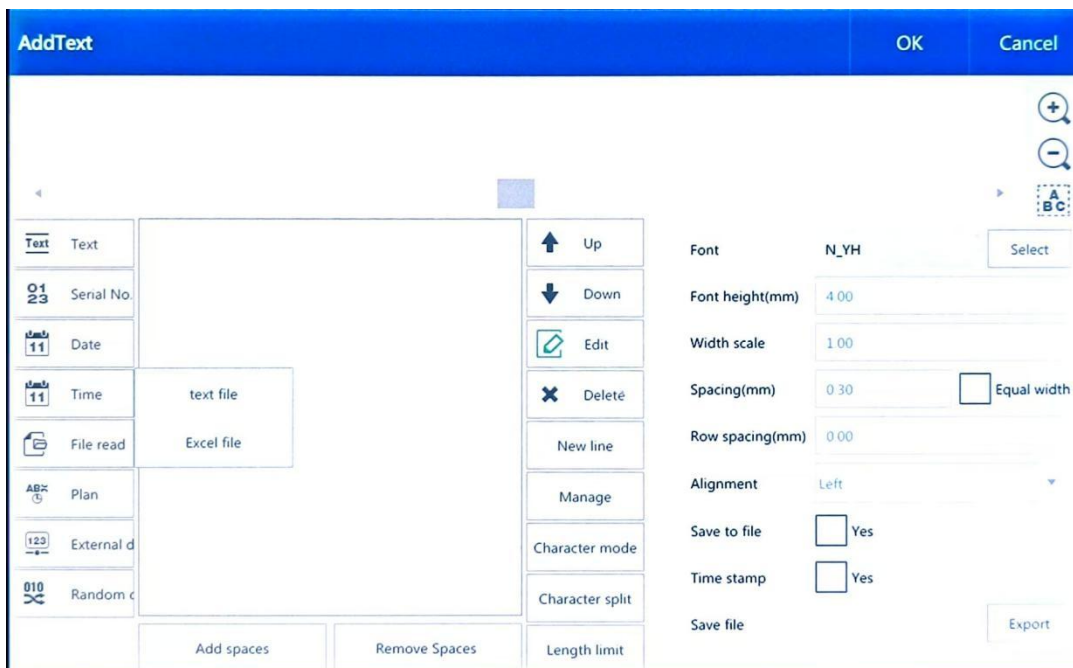
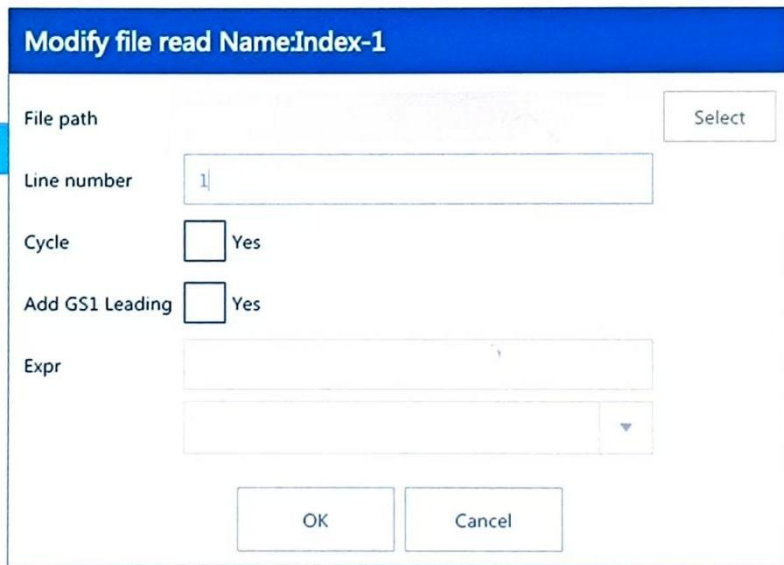

Figure 2-9

Edit text files

Select Text Read and click the Edit button, Pop up file read modification interface .As shown in Figure Figure 2-10.



The image shows a dialog box titled "Modify file read Name:Index-1". It contains the following elements:

- File path:** A text input field with a "Select" button to its right.
- Line number:** A text input field containing the number "1".
- Cycle:** A checkbox followed by the text "Yes".
- Add GS1 Leading:** A checkbox followed by the text "Yes".
- Expr:** A text input field with a dropdown arrow on its right side.
- Buttons:** "OK" and "Cancel" buttons at the bottom center.

Figure 2-10

Select file:

Click on the selection button after the file path , pop up the file path (inside the system or USB), select the file to be loaded, as shown in Figure 2-11.

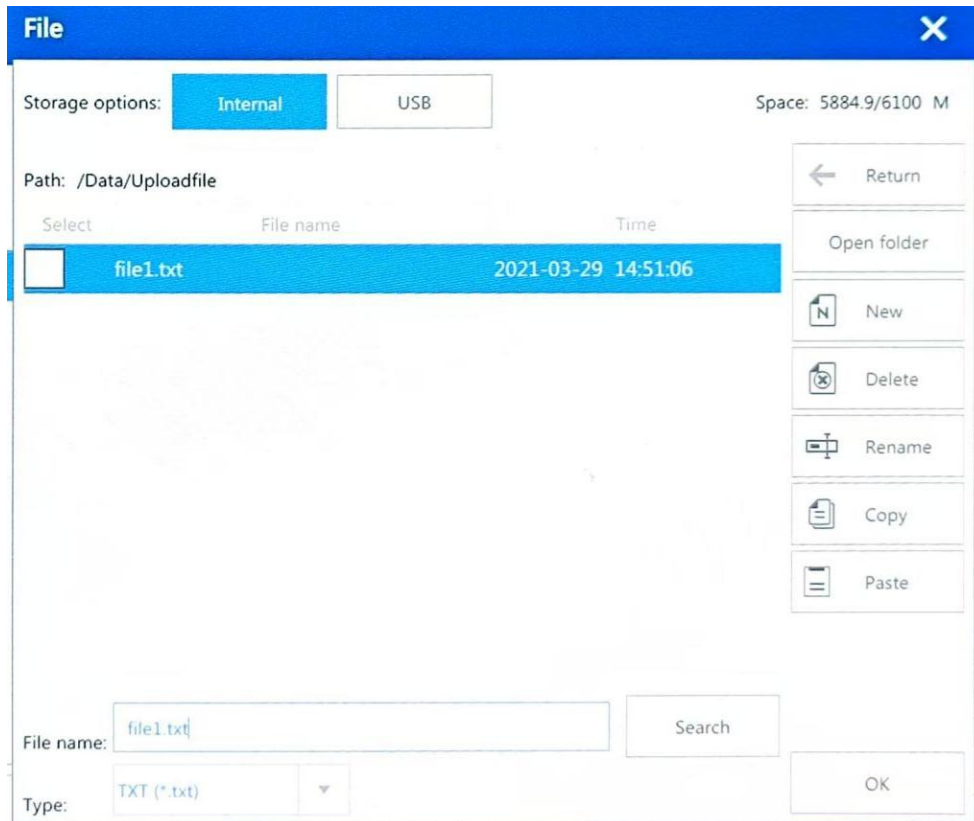

Figure 2-11

Line number: The line number of the text currently being marked

Cycle: whether to cycle to mark the text file, that is, the file label after the last line of content, automatically start from scratch.

Add GS1 Leading: used with customer-specific files.

Edit the excel file

Select Excel Read and click the Edit button, Pop up the Excel read modification interface.

Excel read modify Name:Index-1

File path

Line number (row)

Field name (col) ▼

loop yes

Fixed line mode yes

Repeat count

Current repeat

Expr ▼

Select file

Click on the selection button after the file path , pop up the file path (inside the system or USB), select the file to be loaded, as shown in Figure 2-11.

Line number(row): the line number that is currently being marked. A specific ranks can be selected.

Field name (col): If the table has multiple columns, you can choose to mark a column.

loop: whether the circular mark, that is, the last line of the file,

automatically start from scratch.

Fixed line mode: a fixed line is repeated all the time.

Repeat count: number of single line duplication

Current repeat: a single row of duplicate marks has been marked a few times.

1.3.1.5. Add Plan

Click the Plan button. As shown in Figure 2-12, click the edit button to edit the code skip information, as shown in Figure 2-13.

Add: Add a list of skip code, as shown in Figure 2-14

Delete: Delete the skip code list

Edit: edit the timing skip code information, for example:

Click the edit button in Figure 2-13 to enter the jump code content editing interface, as shown in Figure 2-15. modify the jump code information and start time. Figure 2-14 means

00:00:00-12::00:00 jet code frequency information A,

12:00:00-00:00:00 jet code jump information B

File format: you can select the internal system or the USB file for editing.

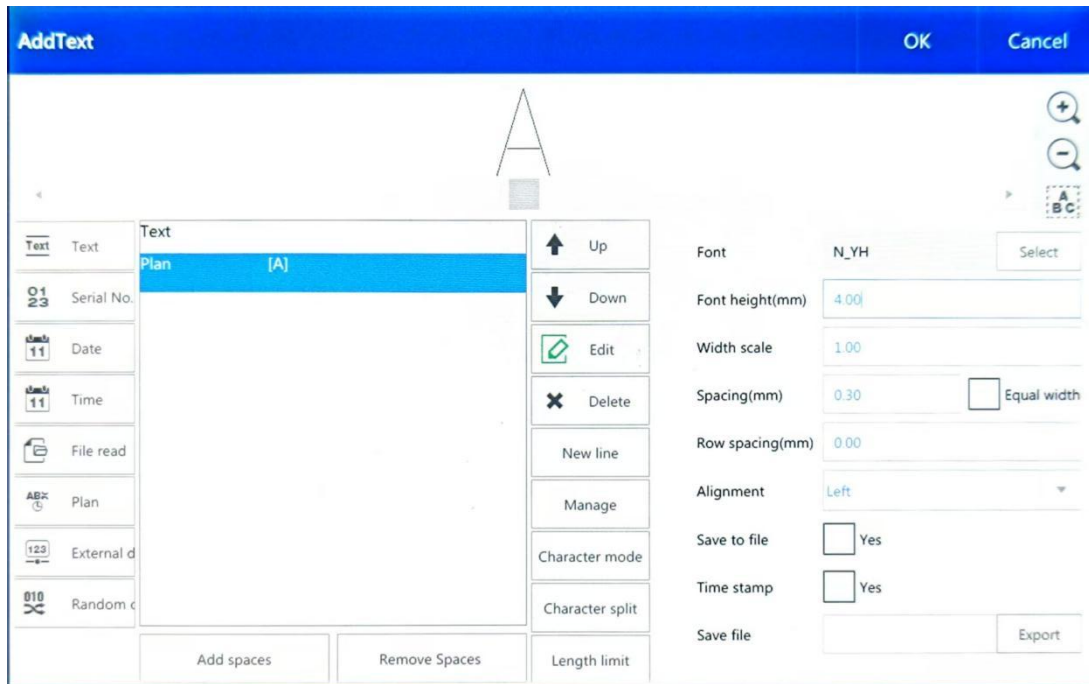

Figure 2-12

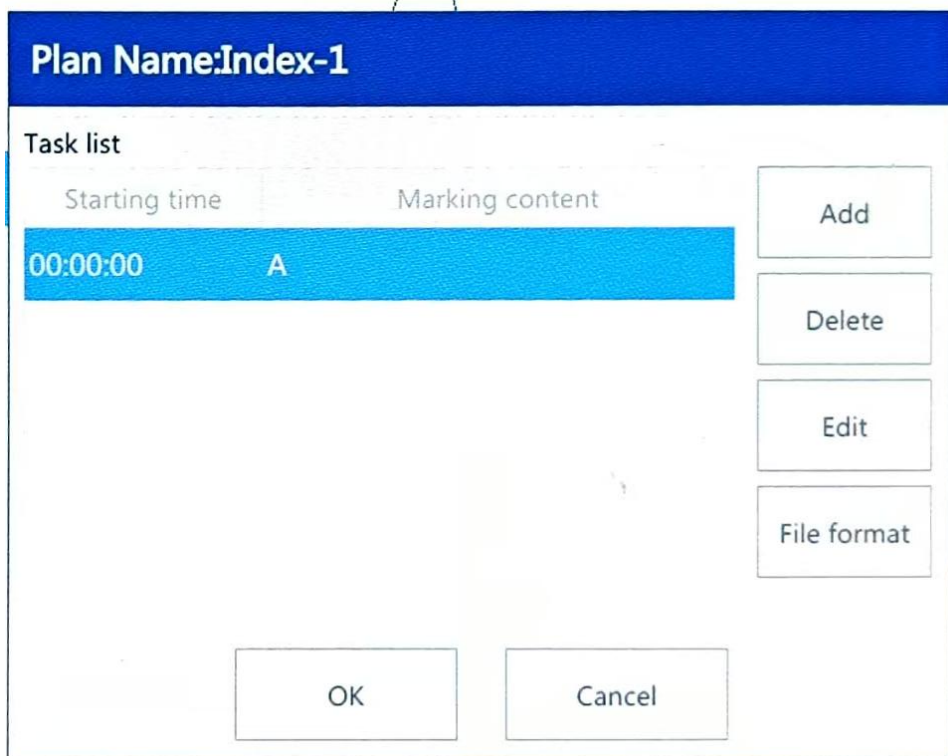

Figure 2-13

Plan Name:Index-1

Task list

Starting time	Marking content
00:00:00	A
12:00:00	B

Buttons: Add, Delete, Edit, File format

Buttons: OK, Cancel

Figure 2-14

Modify

Starting time: 00:00:00

Marking content: A

Buttons: OK, Cancel

Figure 2-15

1.3.1.6. Add external data

Communication function, please contact the engineer.

1.3.1.7. Add random code

The system randomly generates data for marking. Click Edit to enter the random code editing interface.

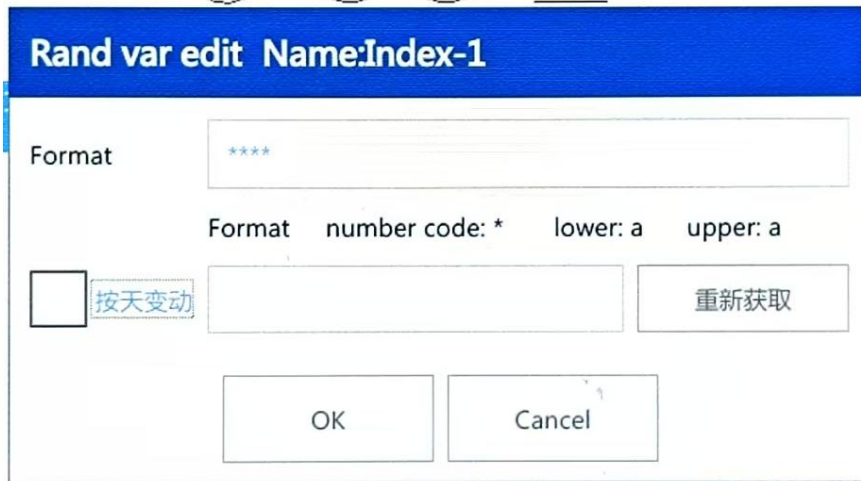
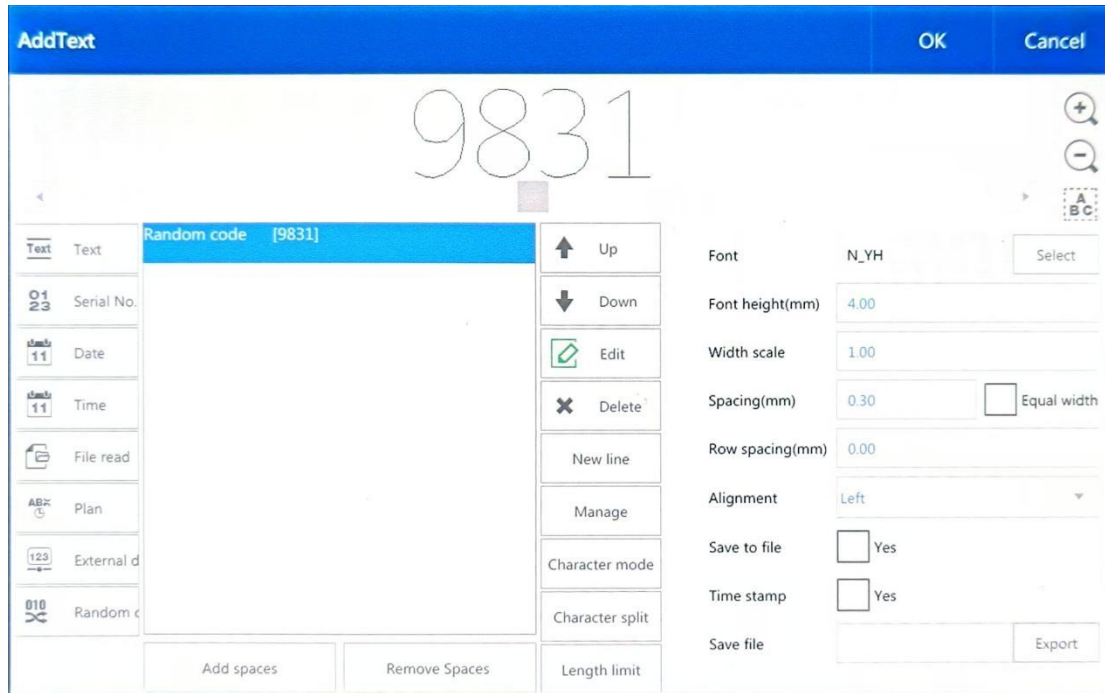

Format description: replace numbers by *, lower case letter with a, and capital letter with A.

Example: * * * aaaAAA, then identify 3 numbers, 3 lower-case letters, and 3 capital letters are combined into a random code.

Change by day: only a fixed random code that day, the next

day change.

1.3.2. Draw

The drawing function includes straight lines, dotted lines, points, circles, rectangles, etc

1.3.2.1. Add Dot

Click on the Dot button in the drawing function. As shown in Figure 2-16, the modification button in the Home can modify its parameters, or select the point pulse output or point time output in the setting- - - -marking parameters, as shown in Figure 2-17.

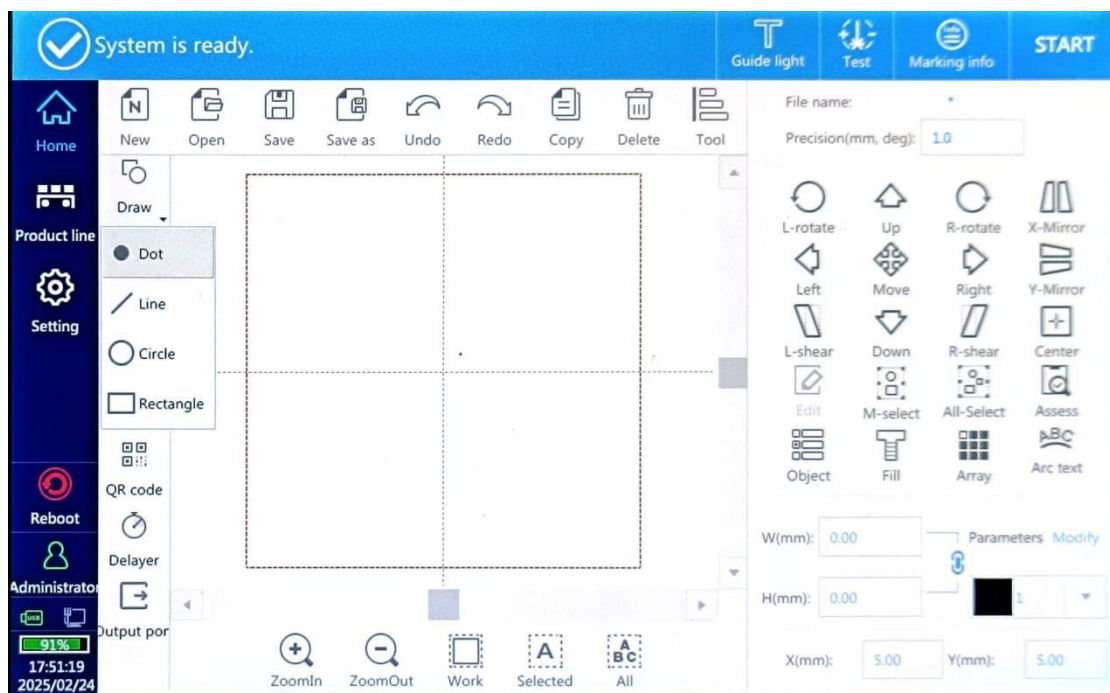

Figure 2-16

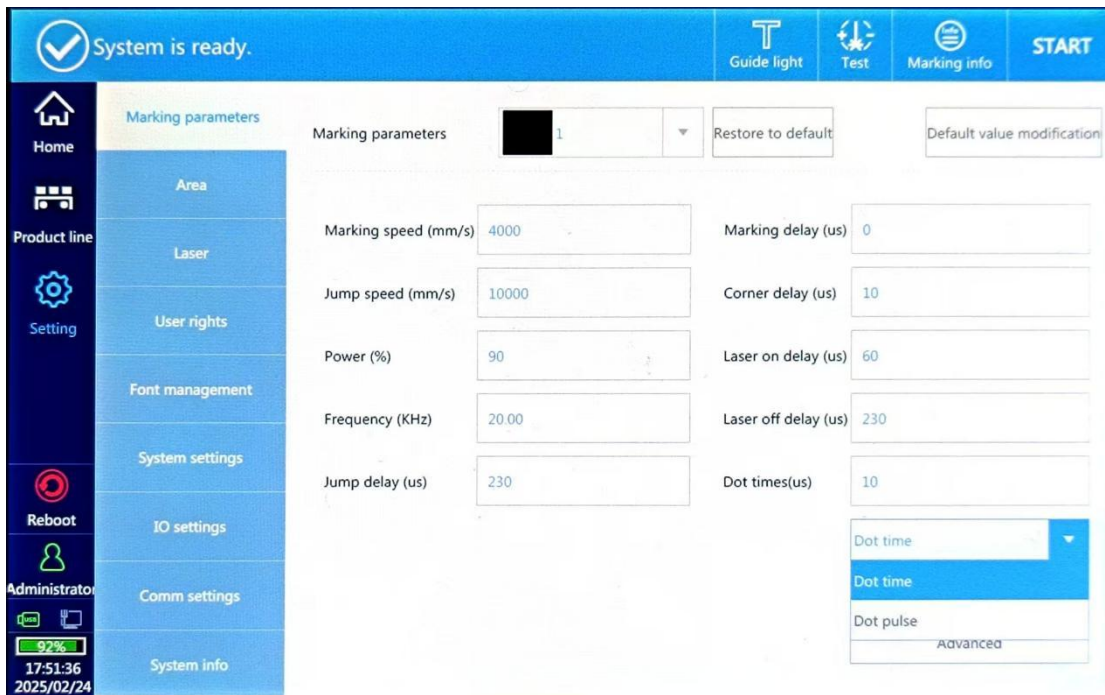
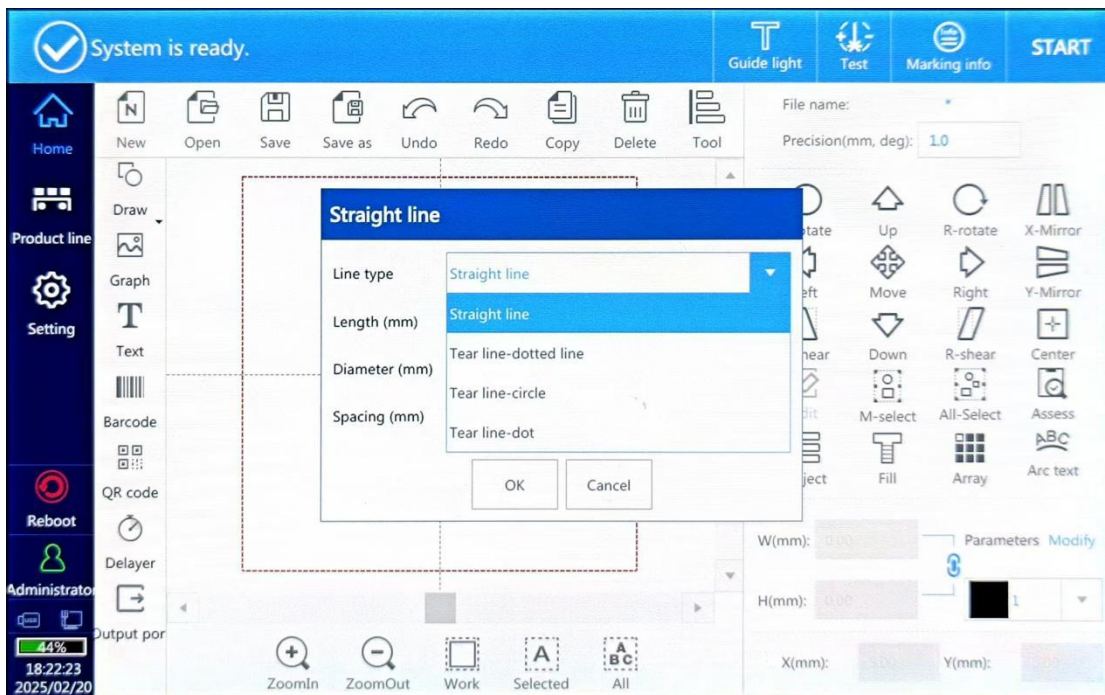

Figure 2-17

1.3.2.2. Add Line

Click on the line button of the drawing function, you can add ordinary straight line, tear line-dotted line, tear line-circle, tear line-dot. As shown in Figures 2-18.



Figures 2-18

1.3.2.3. Add straight line

The line type is straight line and the line length can be set as shown in Figure 2-19 and in Figure 2-20.

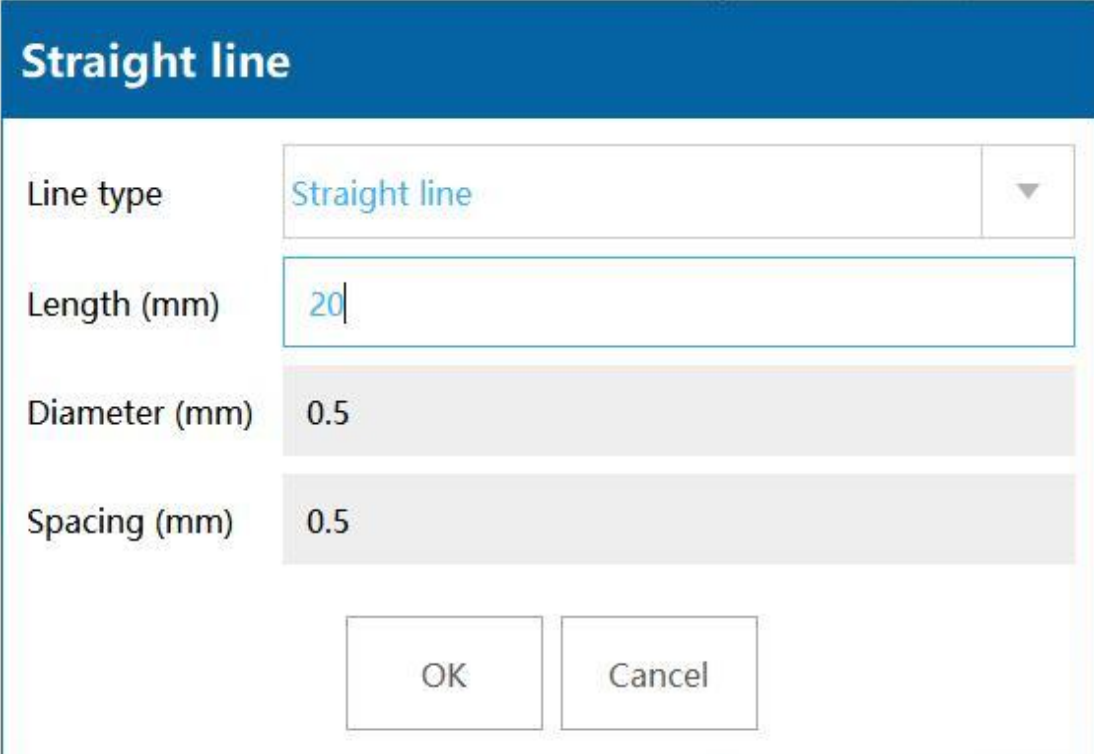

The image shows a dialog box titled "Straight line" with a blue header. It contains four input fields and two buttons. The "Line type" field is a dropdown menu with "Straight line" selected. The "Length (mm)" field is a text box containing "20". The "Diameter (mm)" field is a text box containing "0.5". The "Spacing (mm)" field is a text box containing "0.5". At the bottom, there are "OK" and "Cancel" buttons.

Property	Value
Line type	Straight line
Length (mm)	20
Diameter (mm)	0.5
Spacing (mm)	0.5

Figure 2-19

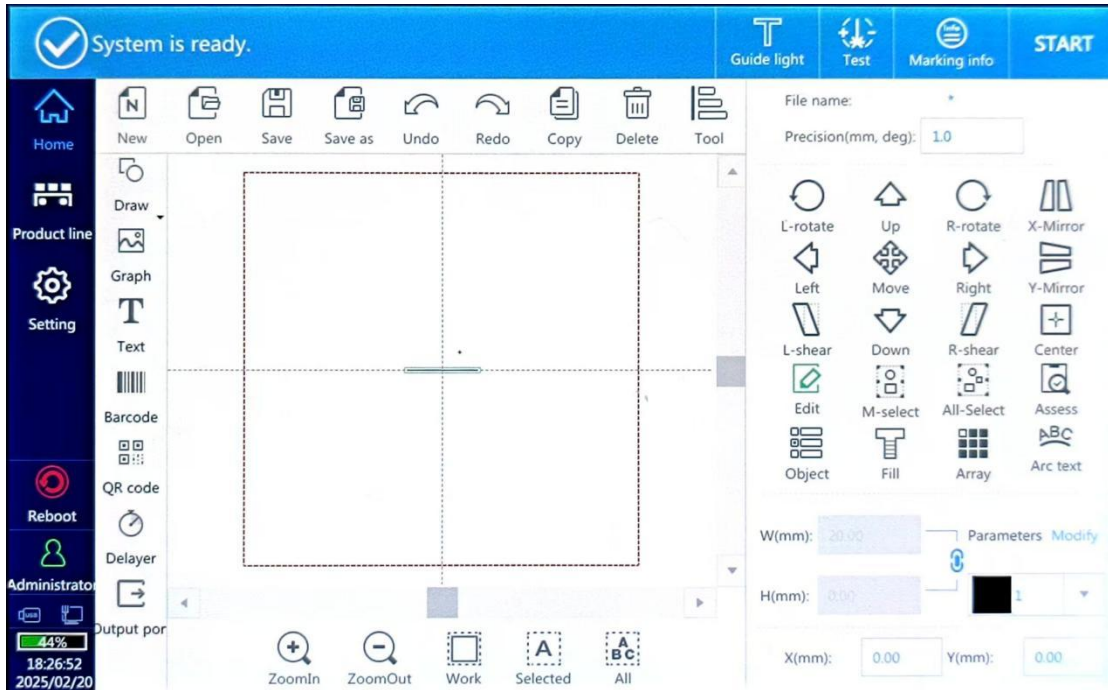

Figure 2-20

1.3.2.4. Add tear line

The tear line type includes dotted lines, circles, or dots, as shown in Figure 2-21, to set the diameter or spacing of each cell.

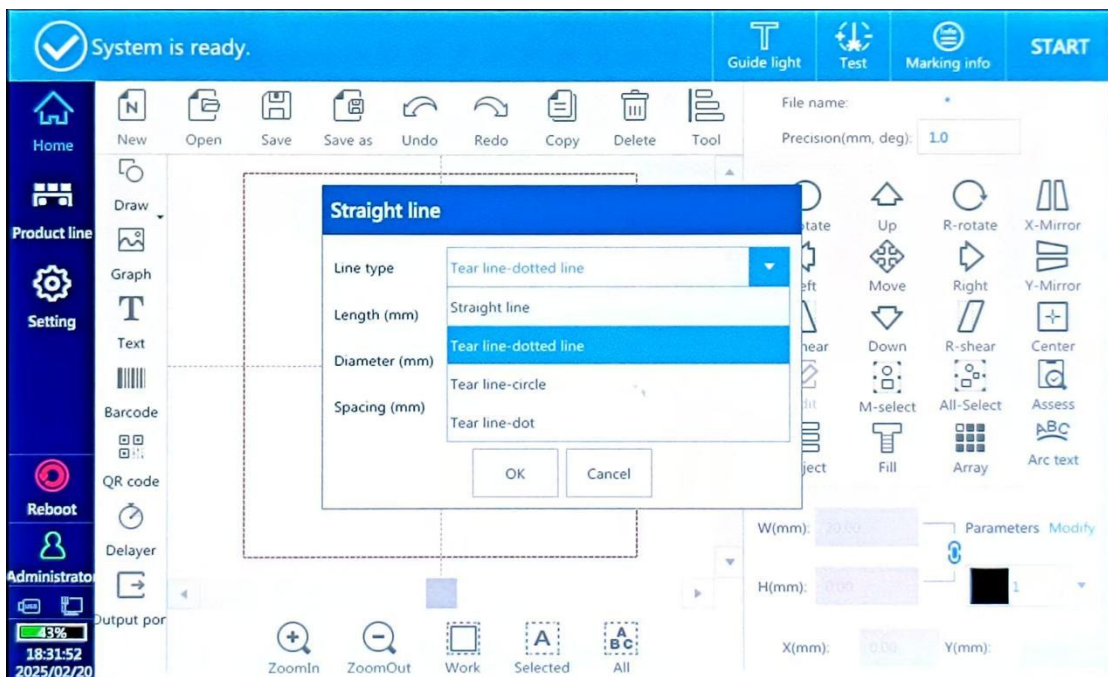

Figure 2-21

1.3.2.5. Add a circle

Click the circle button in the drawing, as shown in Figure Figure 2-22.

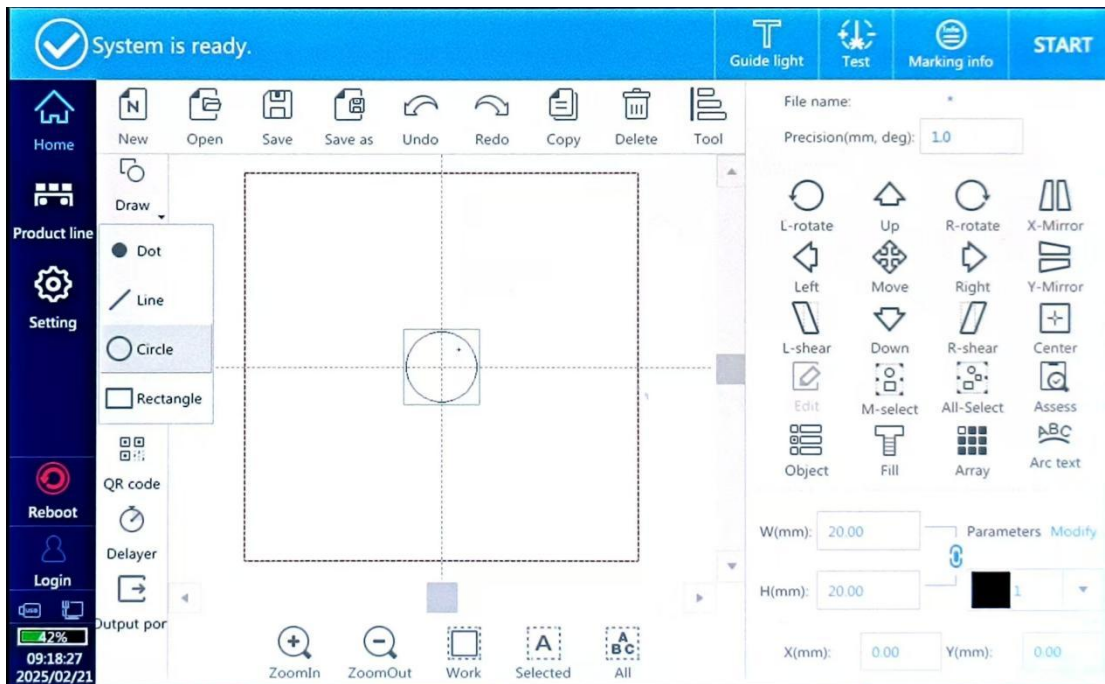

Figure 2-22

1.3.2.6. Add rectangle

Click the rectangular button in the drawing, as shown in Figure Figure 2-23.

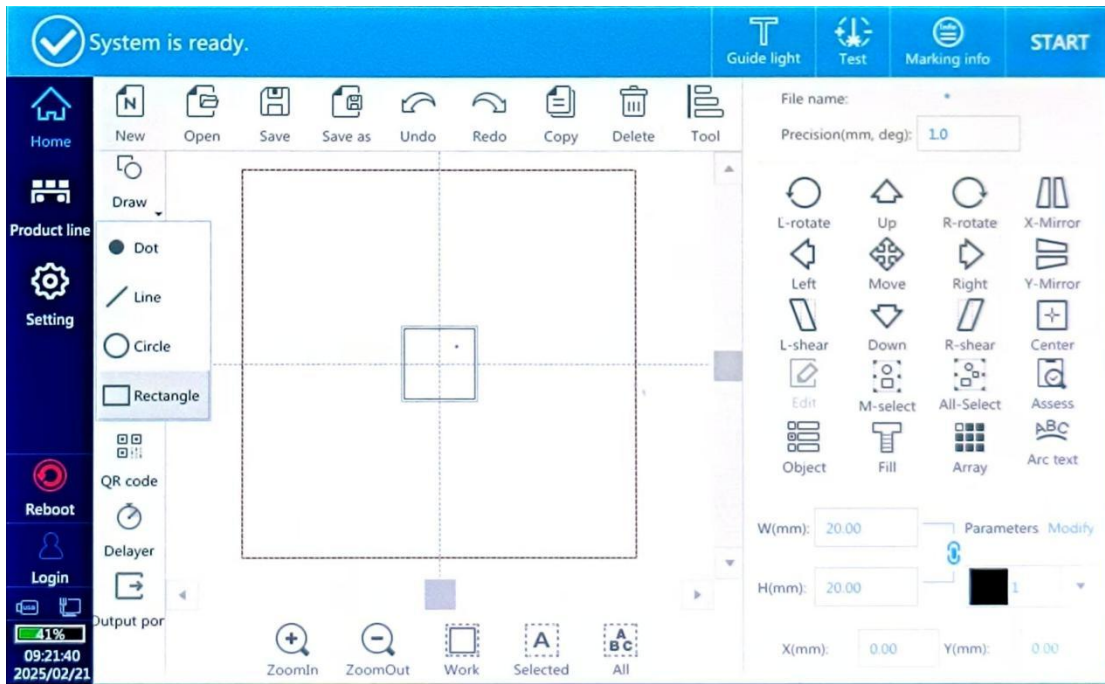

Figure 2-23

1.3.2.7. Add graph

Click the graph button, and the add interface pops up, as shown in Figure 2-24, support format: dxf,plt,jpg,png,bmp.

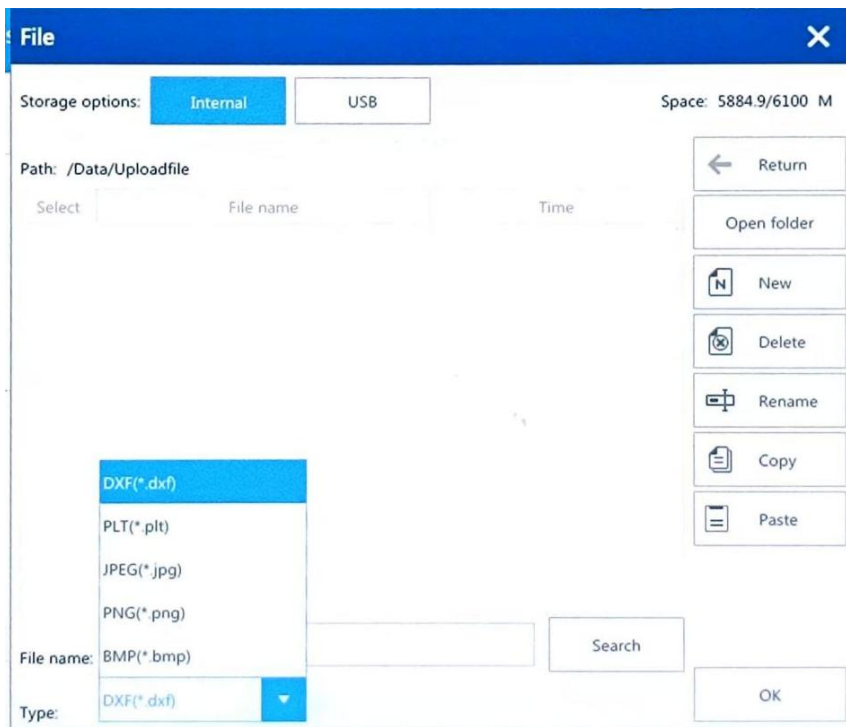

Figure 2-24

1.3.2.8. Add barcode

Click on the barcode button, pop up the content editing interface, the default content is a QR code of 123, as shown in Figure Figure 2-25.

Code

Reverse: after checking the bar code becomes reverse code , the bar code should be set around the border, as shown in the figure below.



(Forward)



(Reverse border)

Type: Select the barcode type, code 2-Of-5 Interleaved, codebar, code 128, code 39,code 93, UPC-A, UPC-E, EAN-14, ITF-14, EAN128, and EAN-13 are optional

Model: Select barcode mode, normal and GS1 (only code 128 and EAN128)

Height: bar code height

Blank: when there is a border, the distance between the bar code and the border

Up/Down:add borders at the upper and lower ends of the barcode can set the number of borders

Left/Right: add borders at the left and right ends of the barcode,

and can set the number of borders.

Text

Display text: After checking, the barcode content will be displayed.

Font: Text content font

Mark parameters: The coding parameters of the displayed text can be modified separately

Font fill: The font fill parameter

Char height: Font height

Width scale: font width

Char space: Character spacing

Line spacing: Font row spacing

Horizontal offset: the offset of the text content in the horizontal direction

Vertical offset: the offset of the text content in the vertical direction

Align orientation: text alignment orientation, divided into up and down, left and right alignment

Alignment: in the same object, multiple lines of content alignment, up and down, in the middle alignment.

Save to the file, time stamp, save file as a record role, usually do not use

Content modification: Click the content box behind the text to enter the content addition interface, as shown in Figure 2-26. After setting it up, click OK to add the barcode. As shown in Figure 2 – 27.

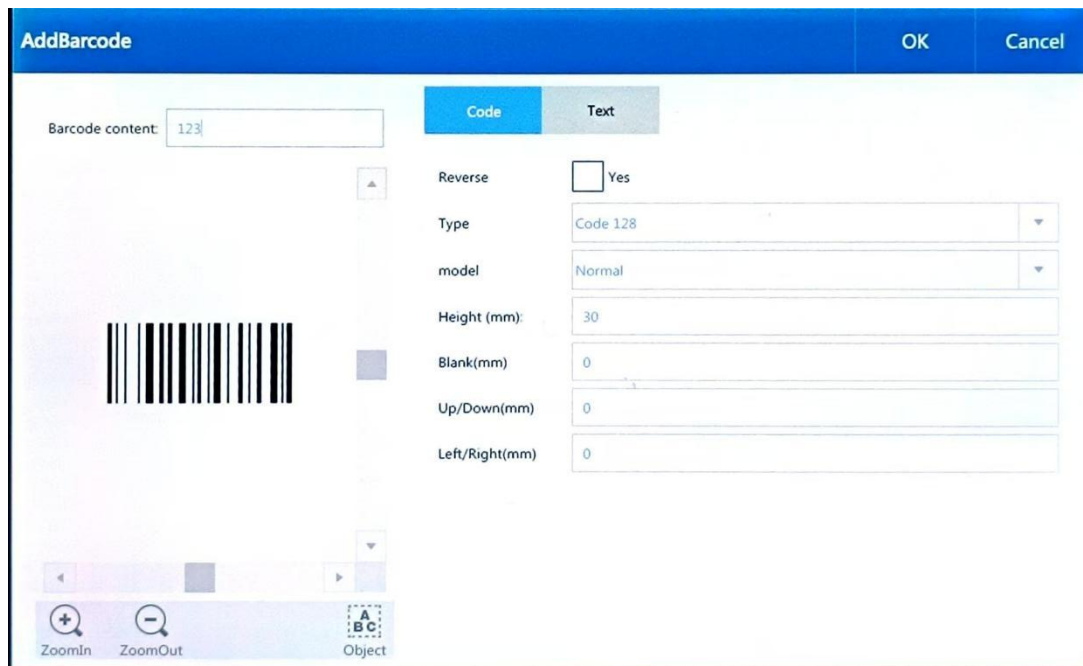

OK Cancel

Code Text

Display text Yes

Font N_SIMPLE Select

Mark parameters Mark parameters

Font fill Fill

Char height(mm) 8.00

Width scale 1.00

Char space(mm) 0.00 Line spacing(mm) 0.00

Horizontal offset (mm) 0.00 Vertical offset (mm) 0.00

Align orientation Right Alignment Center

Save to file Yes Time stamp Yes

Save file Export

Figure 2 – 25

Content changes OK

Content

Text	Text	Text	123
01 23	Serial No.		
11	Date		
11	Time		
File read			
ABX 5	Plan		
123	External d		
010 X	Random c		

Up

Down

Edit

Delete

New line

Character split

Add spaces

Remove Spaces

Figure 2 – 26

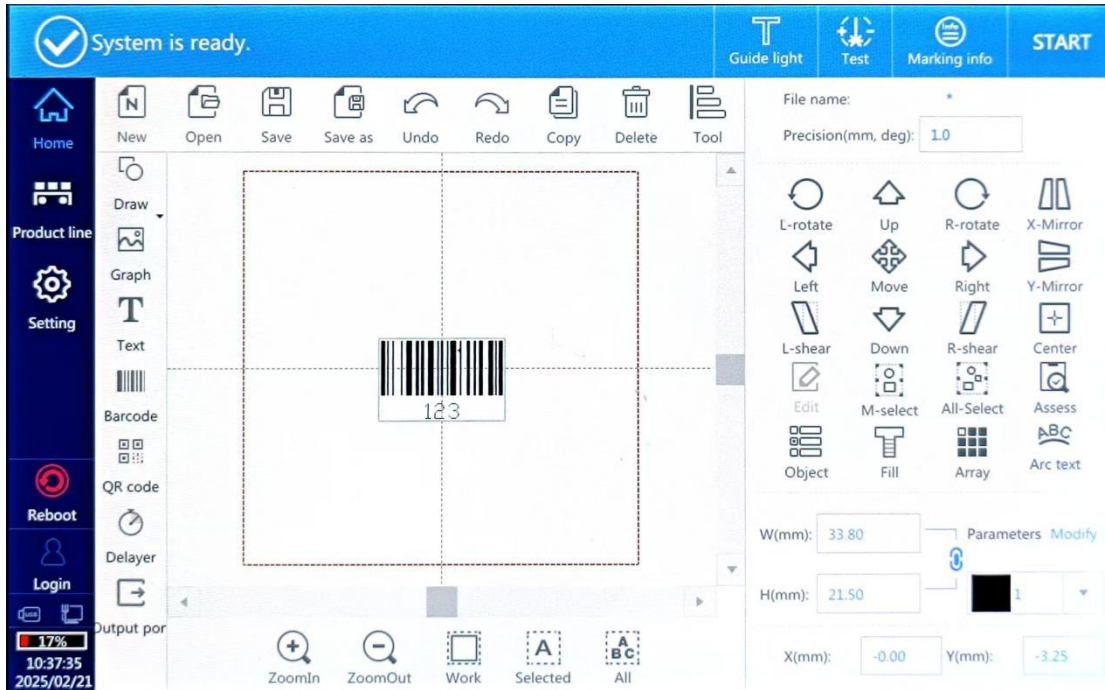

Figure 2 – 27

Fill type modification: Click Fill to enter the fill type modification interface. Fill types include spot, line, circle, ordinary, and multipoint. As shown in Figure 2 – 28.

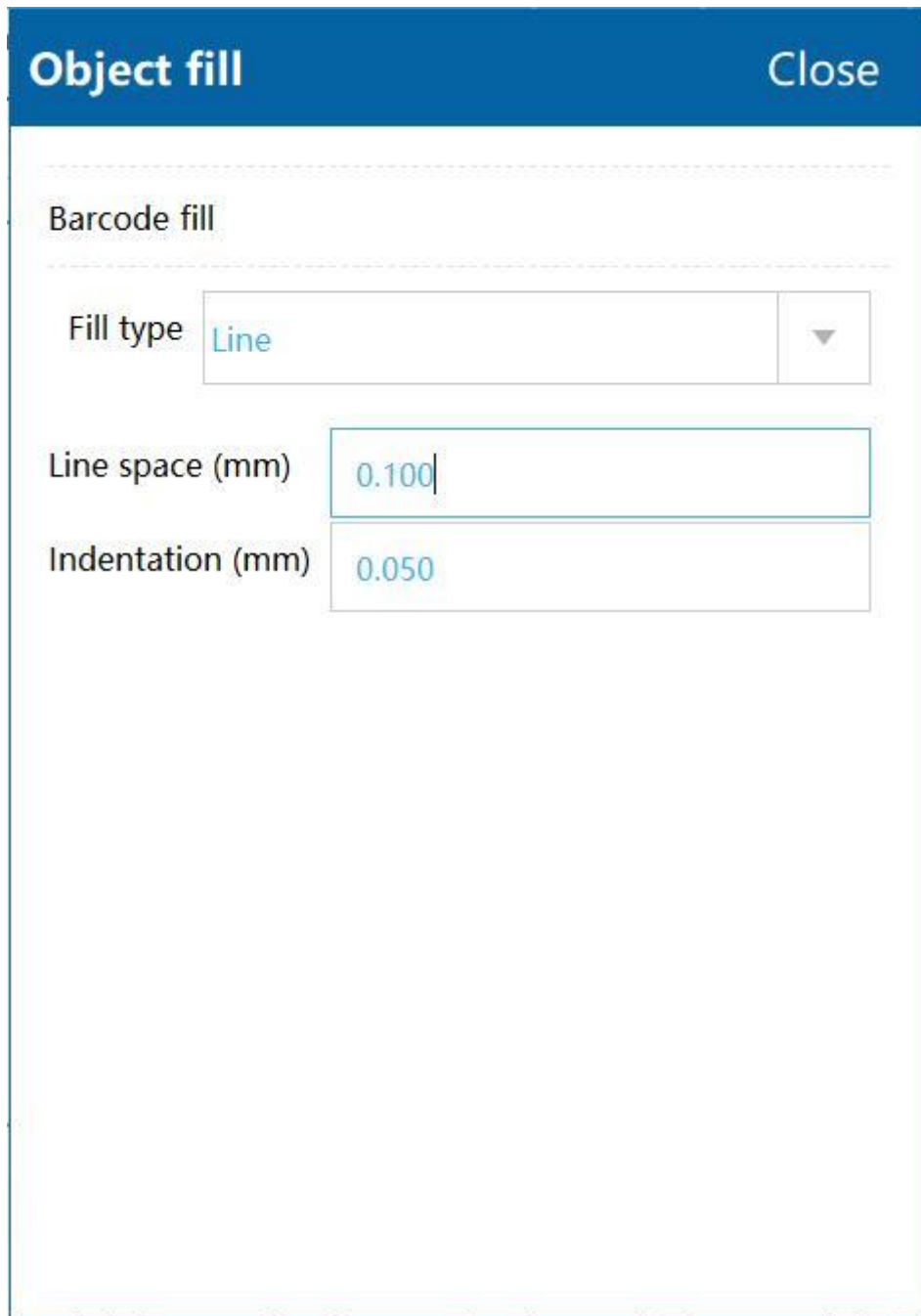

Figure 2 – 28

Spot, line, circle, and multipoint fill

Fill type select the spot, line, circle, multipoint, you can modify line spacing or indentation

Ordinary filling

The filling type is ordinary, as shown in Figure 2-29. Click to

Enable fill, modify the filling angle, fill the line space, and whether to make the frame or not.

Fill type:

Optimization: fill the line in a Z-shaped way

Ordinary: fill the line in the lower direction of the pen

Arch filling: fill the line in the bow shape way

Other parameters: Modify the details of the line filling, as shown in Figure 2-30.

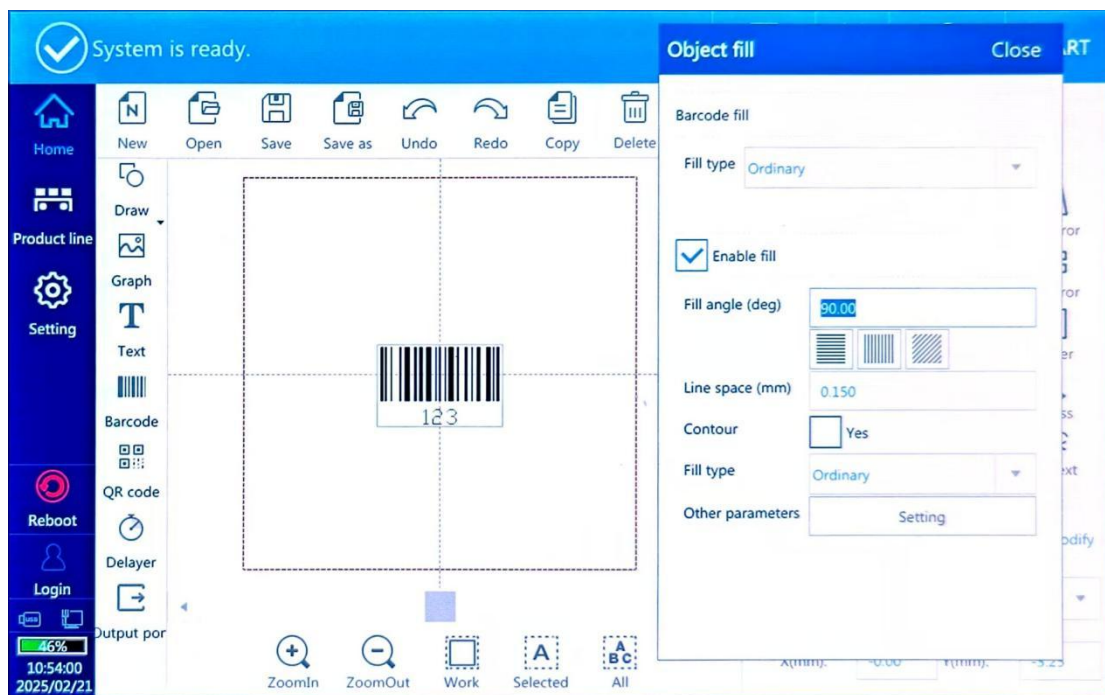

Figure 2-29

Other parameters	
Evenly distributed	<input checked="" type="checkbox"/> Yes
Margin	0.000
Straight indent	0.000
Boundary ring number	0
Ring spacing	0.000
Multiple fills	1
Every offset	0.00
Distribution value	1.000
<input type="button" value="OK"/> <input type="button" value="Cancel"/>	

Figure 2-30

Evenly distributed: Average distribution of filling line spacing

Margin: the distance between the line and the enabling frame

Straight indent: the distance between the line and the enabling frame.

Boundary ring number: the number of borders

Ring spacing: the distance between border and border

Multiple fills: the number of line filling times

Every offset: the angle of last and next offset

Distribution value: Custom distribution filling line spacing

1.3.2.9. Add QR code

Click the QR code button on the home page to enter the QR code editing interface. The default content is the QR code of

123, as shown in Figure 2-31.

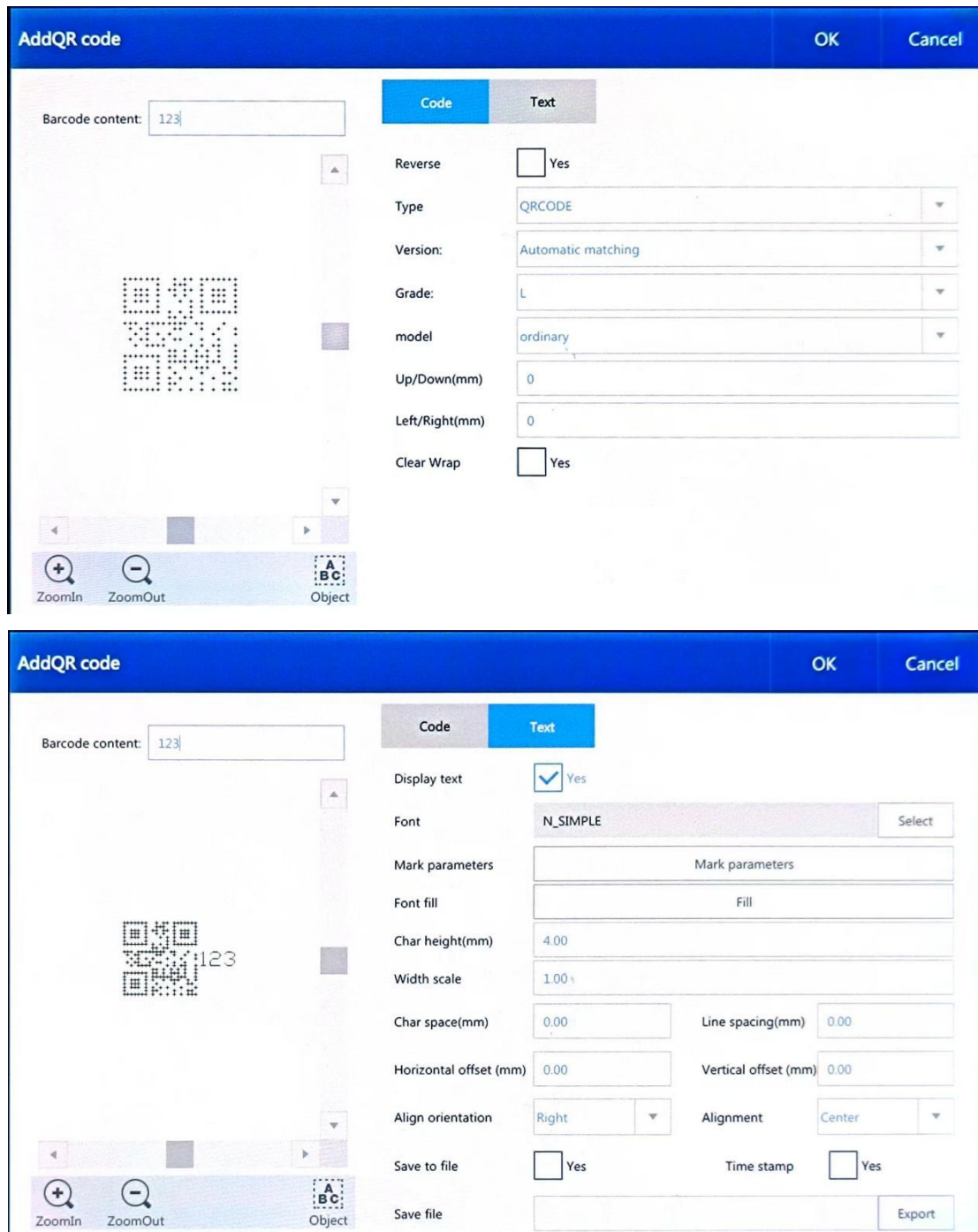
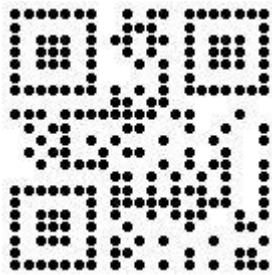

Figure 2-31

Code

Reverse: after checking the QR code reverse, reverse generally need to add four borders, is the upper and lower

frame, left and right borders, are changed to 1, the comparison is as follows:



(Forward)

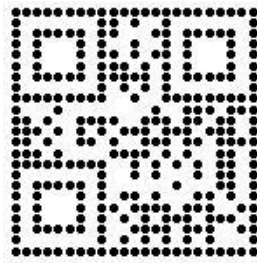

(Reverse border)

If the contrast is not enough, the barcode is required in reverse, and an outer box should be added. Example: The white cover with the black QR code does not need to reverse, the brown lid needs to reverse the frame, as shown below.



Type: Optional types: QR CODE, PDF417, DATAMATRIX, Micro QR Code, Chinese-Sensible

Version: QR code version size

Grade: two-dimensional code error correction level, divided into four levels, the higher the level, the higher the recognition rate corresponding, but the longer the spray time.

border: The number of borders added. Example: 1 is 1 unit border and 2 is 2 unit borders, as shown below.

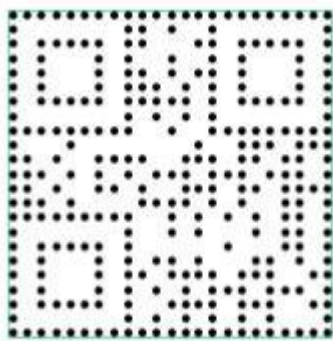

1 unit border



2 unit border

When selecting DATAMATRIX as the QR code type, the mode of the code can be changed to ordinary or GS1.

When selecting GS1, a prompt will appear saying "Parameter data error, please reselect". Click OK, then click on the barcode content to enter the GS1 data addition interface. Click Add and select one of the modules, as shown in the figure.

Then click Exit to return to the QR code interface, switch the mode to ordinary and then switch to GS1 again.

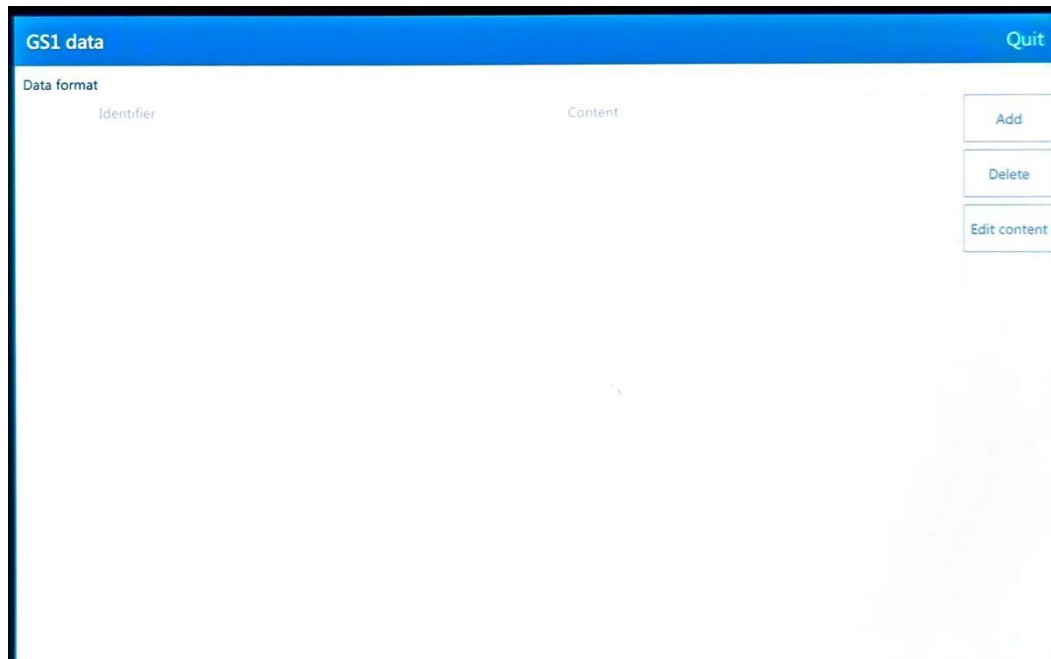

Text

Display text: display the content of the QR code

Font: Select the QR code content font

Mark parameters: The coding parameters of the displayed text can be modified separately

Font fill: The font fill parameter

Char height: Font height

Width scare: font width

Char space: Character spacing

Line spacing: Font row spacing

Horizontal offset: the offset of the text content in the horizontal direction

Vertical offset: the offset of the text content in the vertical direction

Align orientation: text alignment orientation, including up and down, left and right alignment.

Alignment: in the same object, multiple lines of content alignment, up and down, in the middle alignment.

Save to file, time stamp, save file as a record role, usually do not use.

Content modification: Click the content box behind the text to enter the content addition interface, as shown in Figure 2-32. After setting up, click OK to complete the addition of QR code, as shown in Figure 2-33.



Figure 2-32

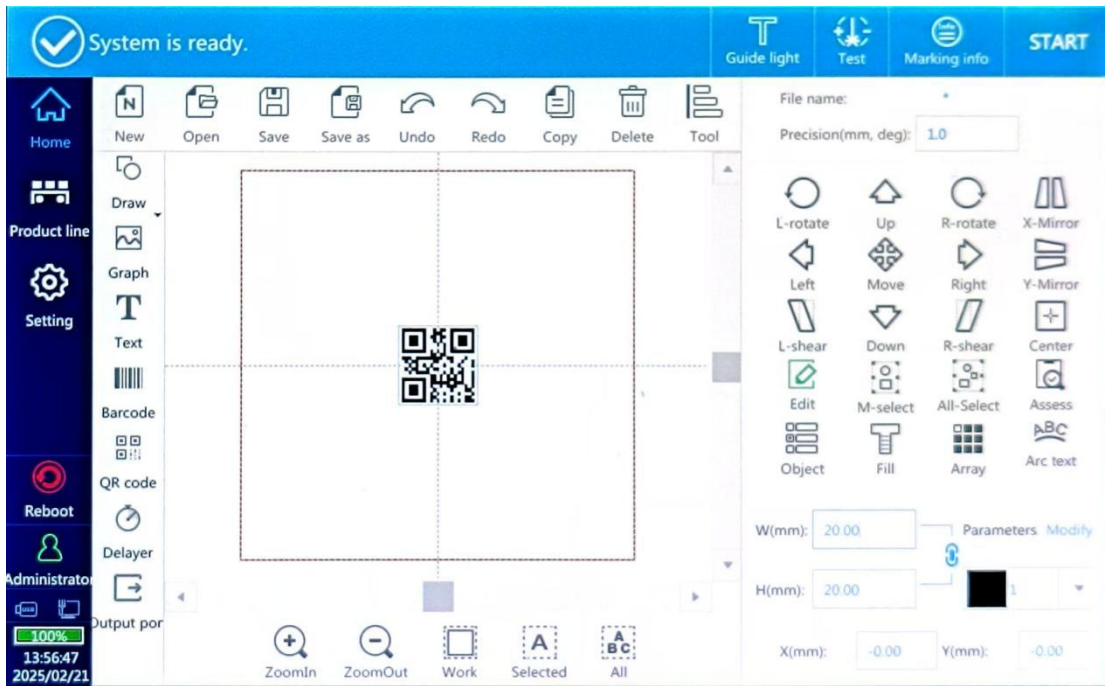

Figure 2-33

QR code filling

Click Fill and select the barcode filling method, as shown in Figure 2-34.

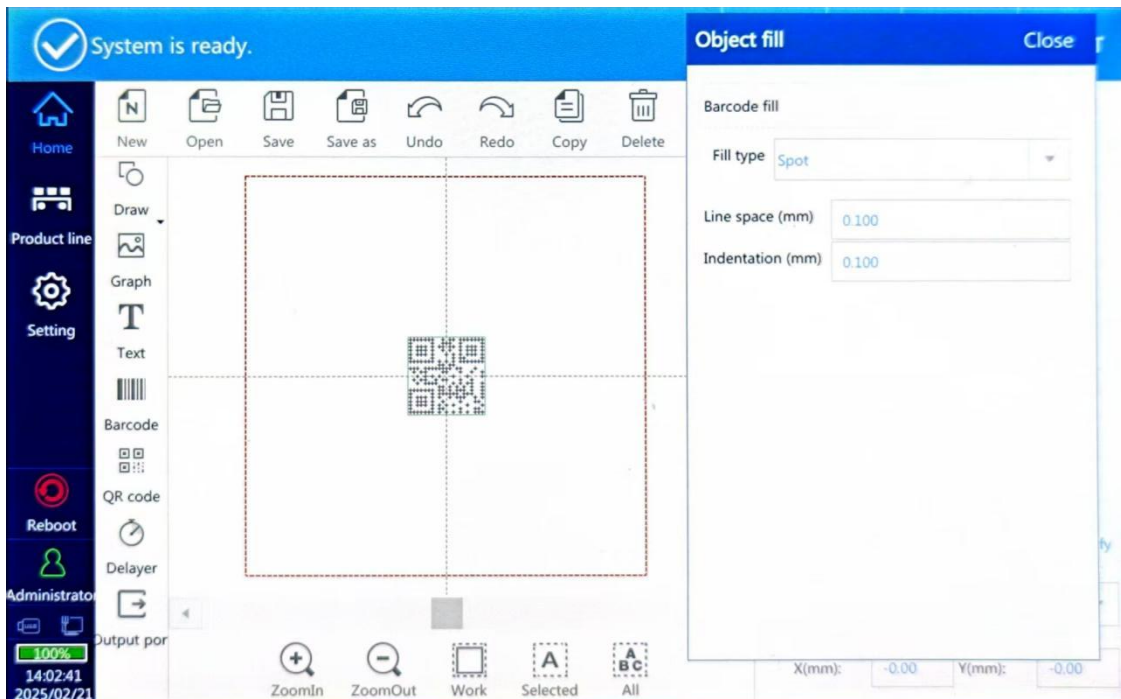

Figure 2-34

Fill type: select the fill method of bar code, can select spot, line, circle, ordinary, multipoint

Spot fill: Add a QR code with (ABCDEFGH1234567980), select spot fill in fill type, as shown in Figure 2-35.

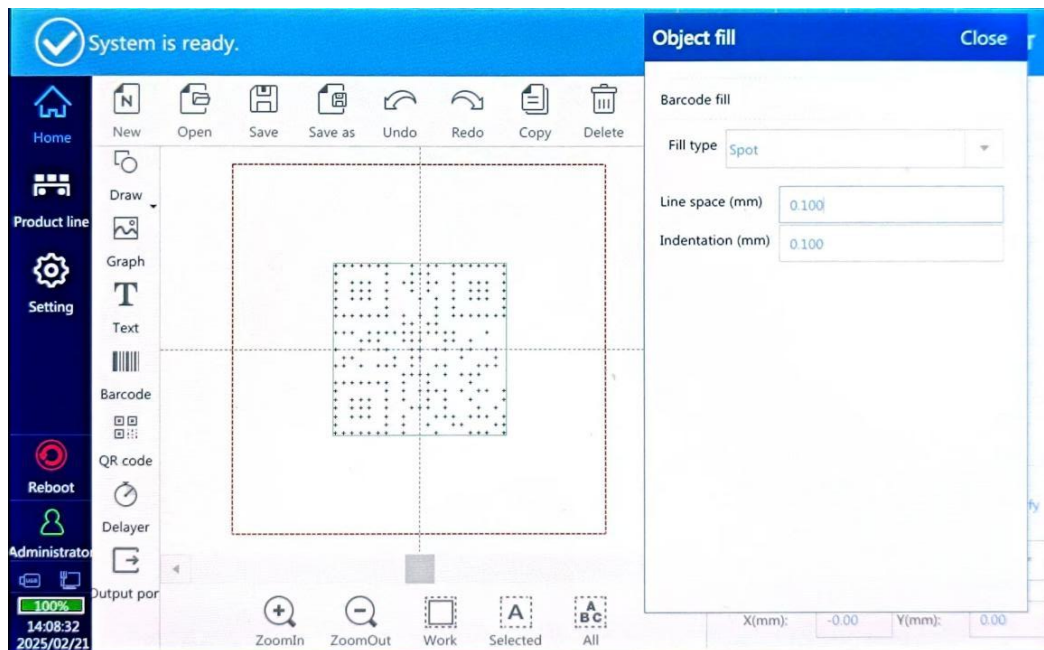

Figure 2-35

Line filling:

Add a QR code of (ABCDEFGH1234567980) (line spacing: 0.2mm, indentation: 0.1 mm), select line filling in the fill type, as shown in Figure 2-36, change the spacing or edge spacing (line spacing: 1 mm, indentation: 0.2mm), as shown in Figure 2-37.

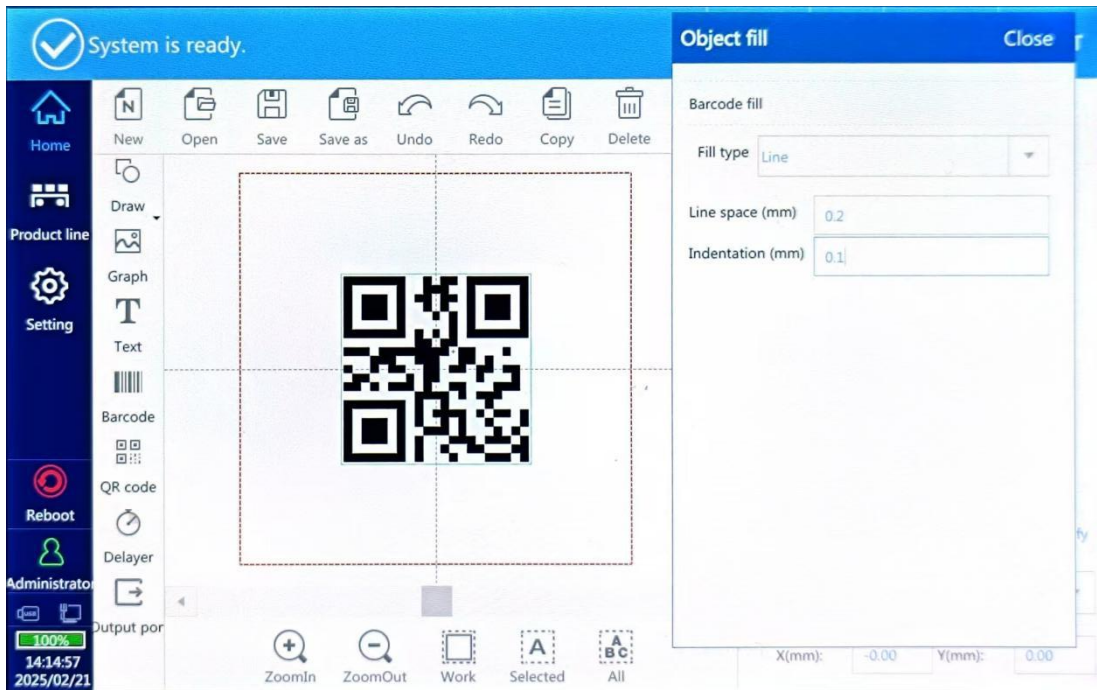

Figure 2-36

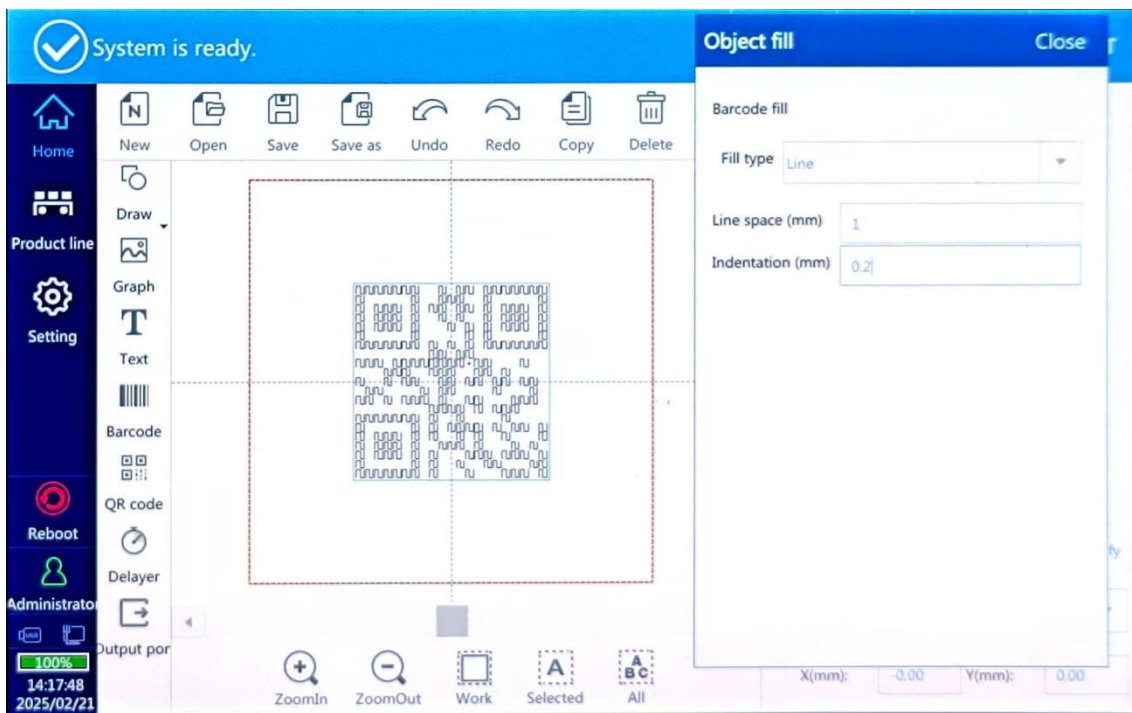

Figure 2-37

Circle filling:

Add a QR code with (ABCDEFGH1234567980) (line spacing: 0.1, indentation: 0), select the circle fill in the fill type, as shown

in Figure 2-38, change the spacing or margin (line spacing: 0.5 mm, indentation: 0.05mm) as shown in Figure 2-39.

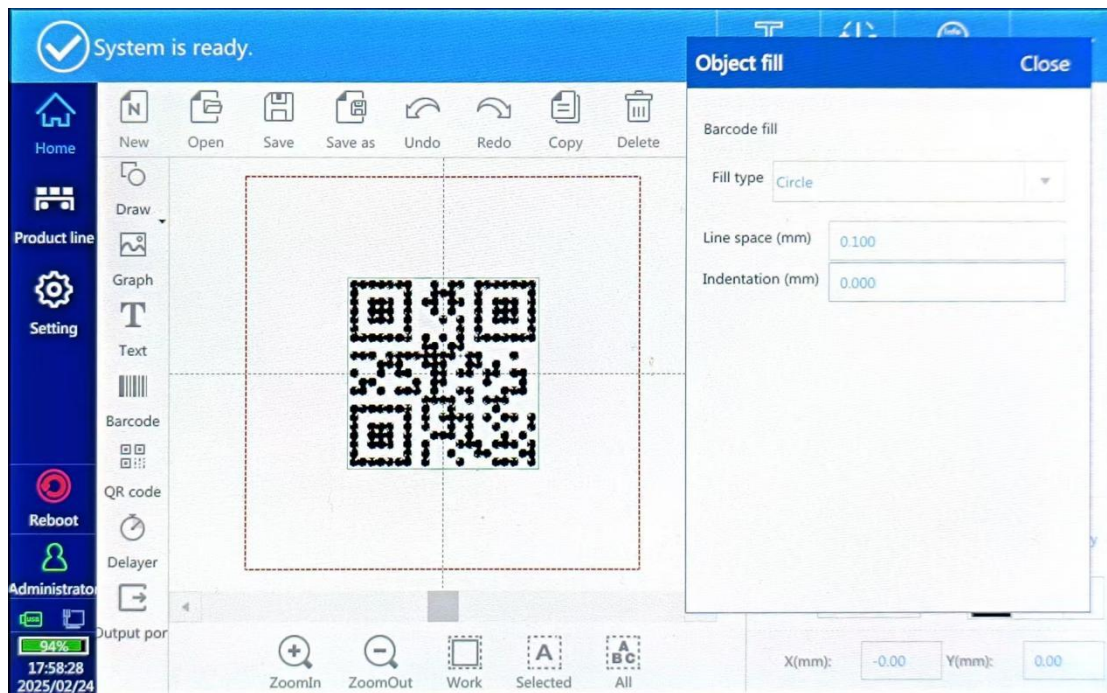

Figure 2-38

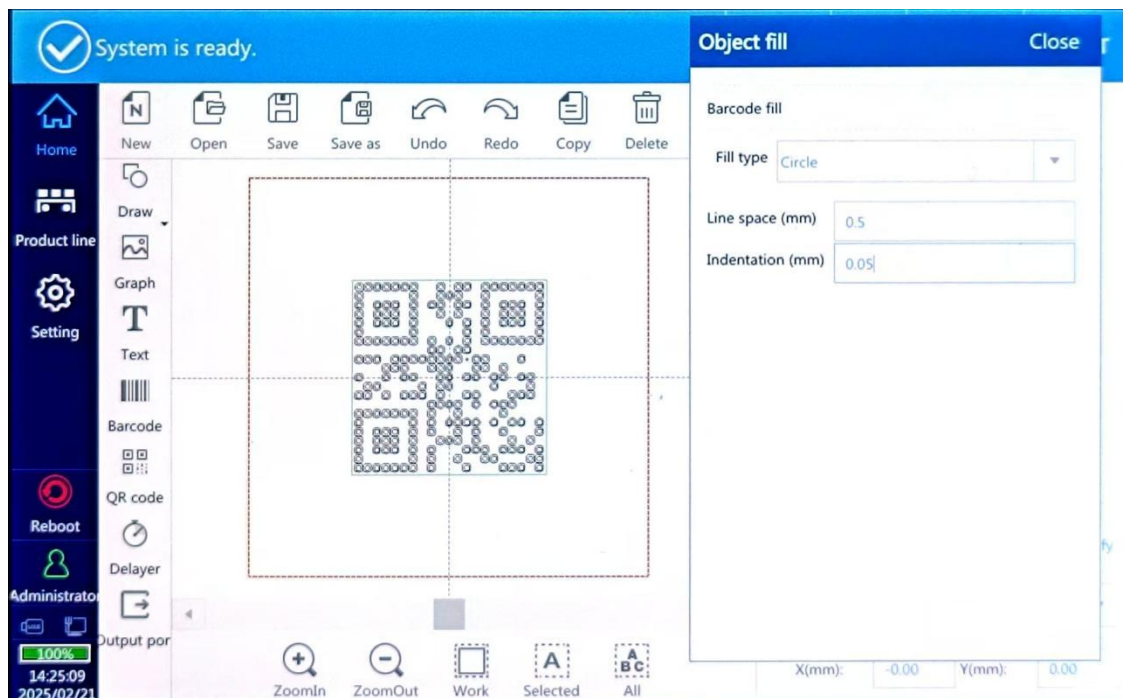

Figure 2-39

Ordinary filling:

Add a QR code with (ABCDEFGH1234567980) and select ordinary fill in the fill type.

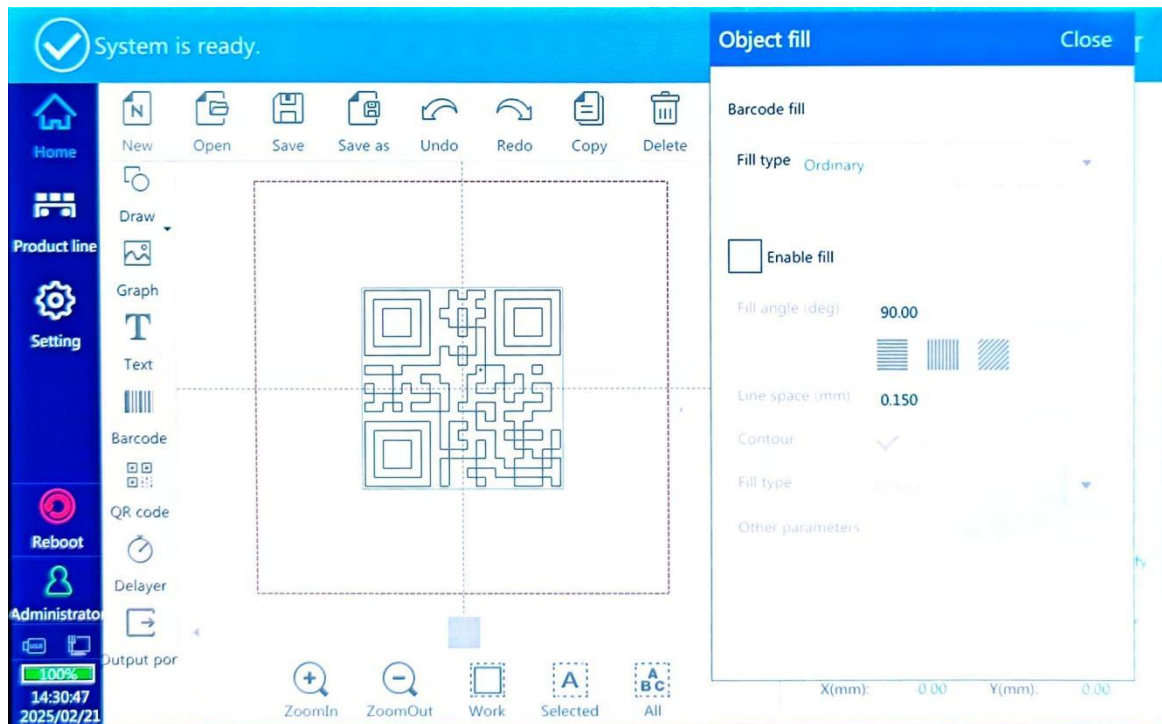

Figure 2-40

Select the enabling fill, as shown in Figure 2-41, can change the filling angle, line space, whether the enabling box, select the line filling type (consistent with the barcode fill type), QR code effect is shown in Figure 2-42.

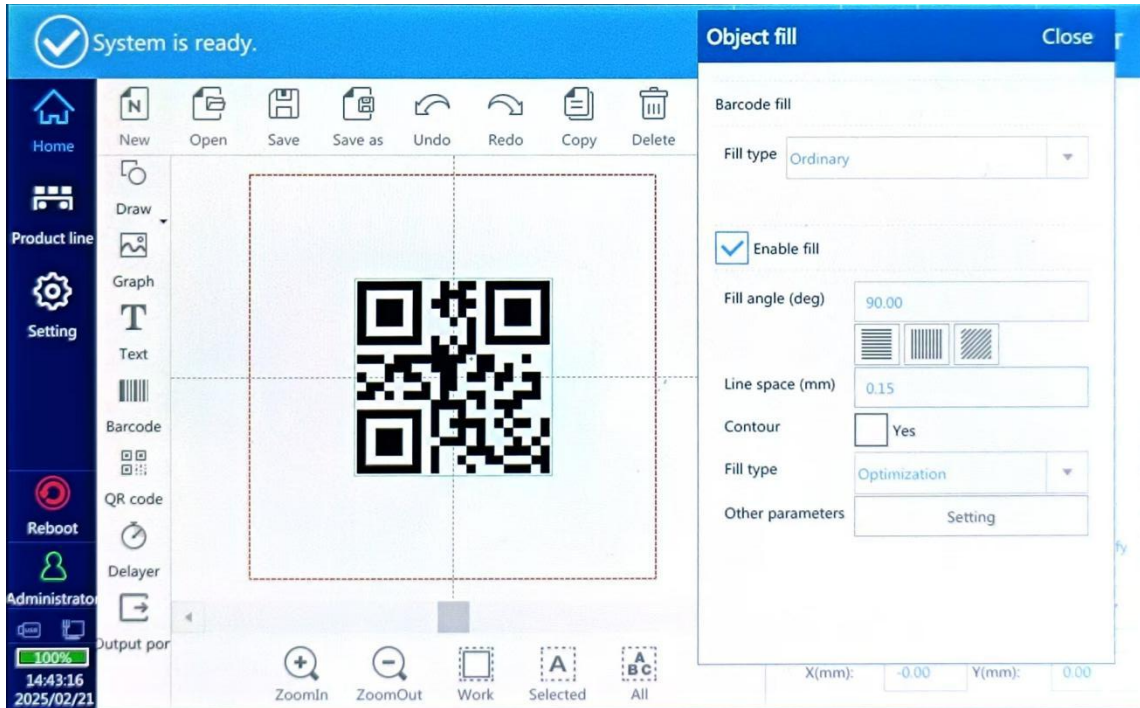

Figure 2-41

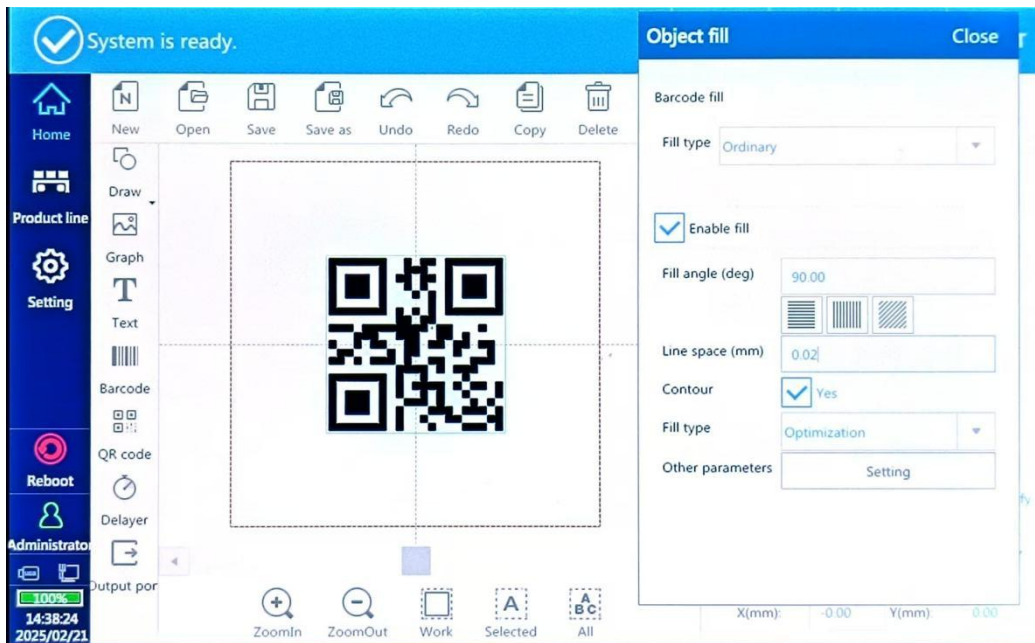

Figure 2-42

Other parameter: as shown in Figure 2-43

Other parameters	
Evenly distributed	<input checked="" type="checkbox"/> Yes
Margin	0.000
Straight indent	0.000
Boundary ring number	0
Ring spacing	0.000
Multiple fills	1
Every offset	0.00
Distribution value	1.000
<input type="button" value="OK"/> <input type="button" value="Cancel"/>	

Figure 2-43

Evenly distributed: Average distribution of filling line spacing

Margin: the distance between the line and the enabling frame

Straight indent: the distance between the line and the enabling frame

Boundary ring number: the number of borders

Ring spacing: the distance between border and border

Multiple fills: the number of line filling times

Every offset: the angle of last and next offset

Distribution value: Custom distribution filling line spacing

Multi-point filling:

Add a QR code with (ABCDEFGH1234567980) (line spacing: 0.1mm, indentation: 0 mm), select multipoint fill in fill type, as

shown; change the spacing or edge spacing (line spacing: 0.5 mm, indentation: 0.05mm), as shown in the figure.

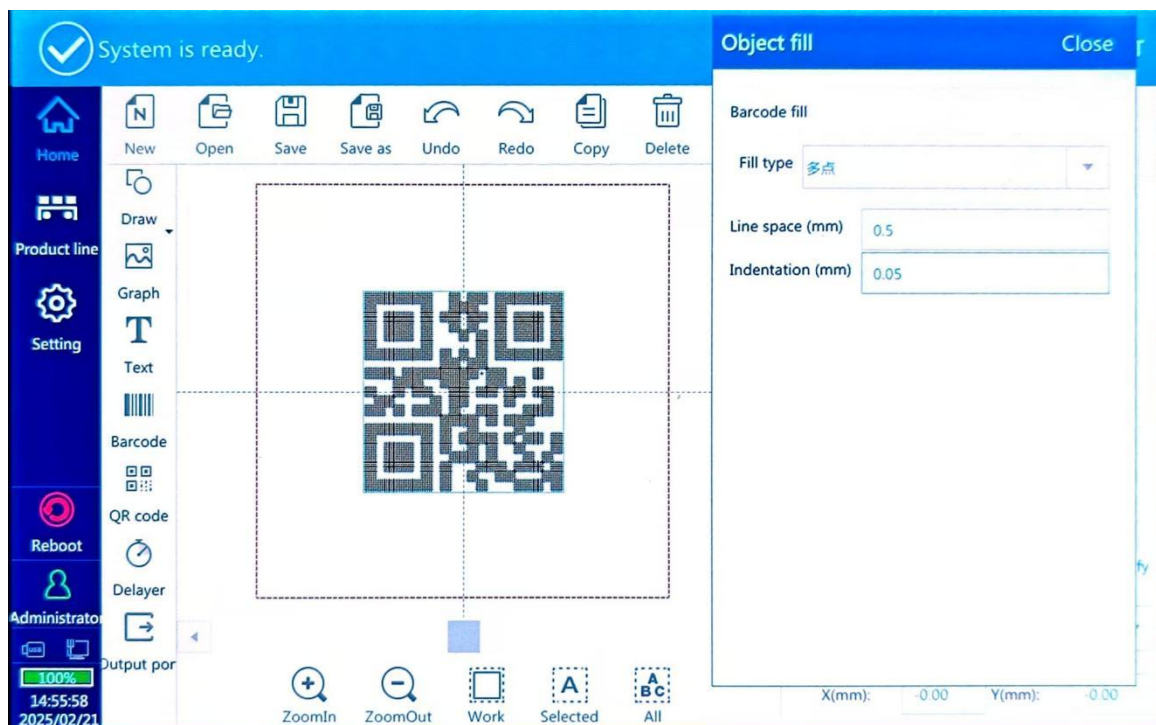
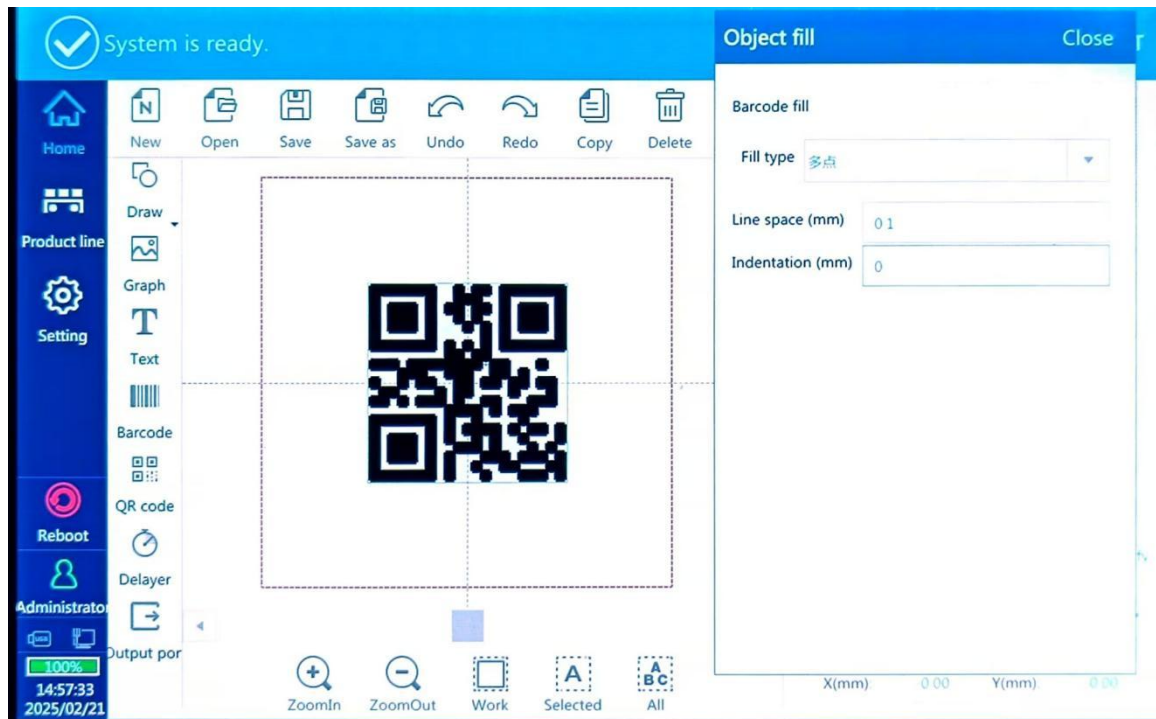

1.3.2.10. Add delayer

Click the home page delayer button, pop up the editing

interface, can modify the time of the delay device, this function only works for the static function, and the delay device must be added before the mark object, can adjust the position of the delay device in the object list, as shown in Figure 2-44.

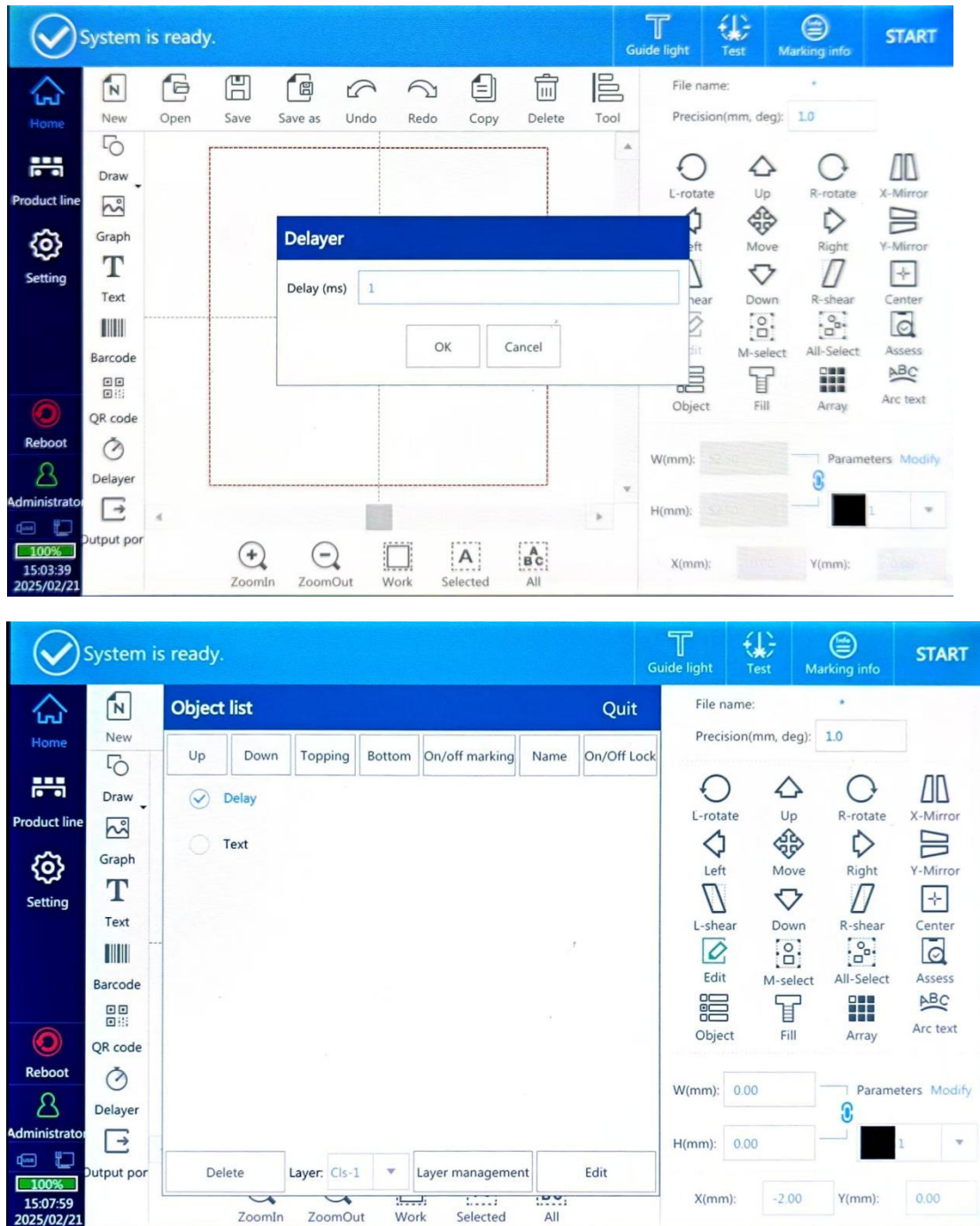

Figure 2-44

1.3.2.11. Output port

Set the output time and the output port, it is the function of a customized machine.

1.3.3. New

Click on the new button. Pop up the interface for whether to save the previously edited data. If you want to save, click OK, then the save data file interface will pop up. Enter the name (e.g. 123) and the save path is:/ to save the file, as shown in Figure 2-45.

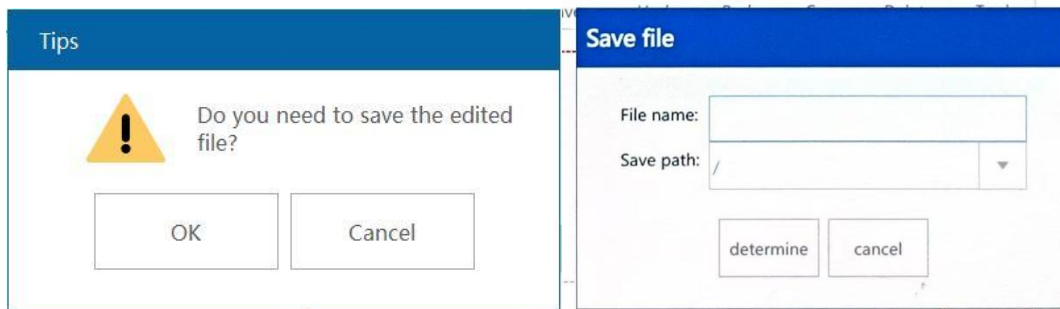

Figure 2-45

1.3.3.1. File open

Click open button. Open the file stored in the system internal file or USB, select USB file 123, click OK, as shown in Figure 2-46.

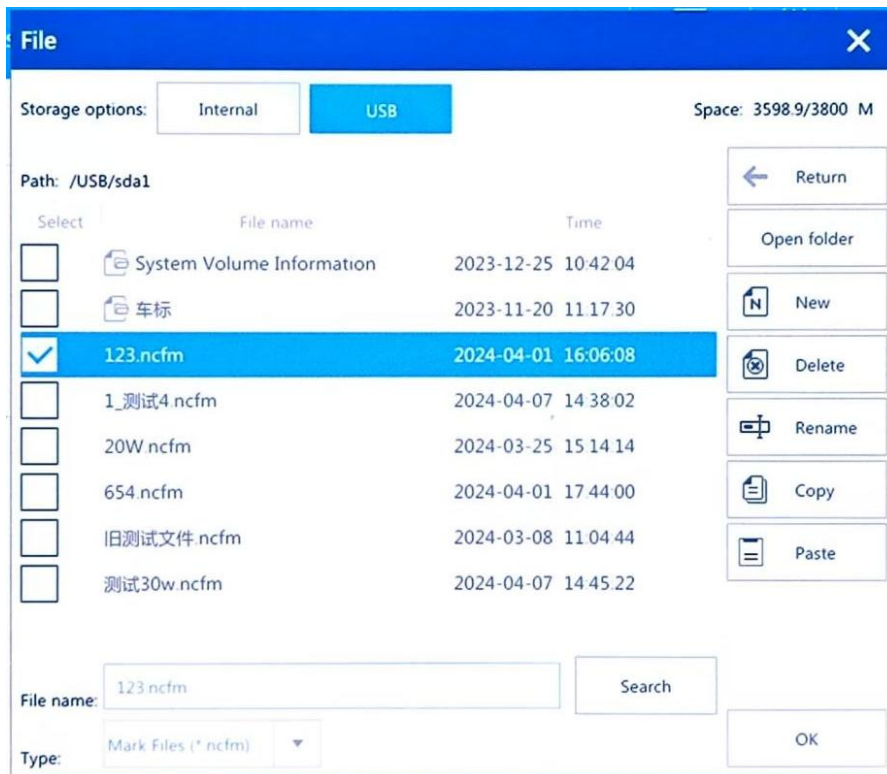

Figure 2-46

Return: Return to the previous level directory

Open Folder: Select Open Folder and open

New: New file

Delete: Delete the file

Rename: Rename the file

Copy: Copy files (to copy files inside USB or copy internal system files to USB)

Paste: paste the copied file

1.3.3.2. Save

Save the file

1.3.3.3. Save as

Save as the file

1.3.3.4. Undo

Cancel the last operation

1.3.3.5. Redo

Implement the last revocation action

1.3.3.6. Copy

Copy the selected data, and then click on the blank area to automatically paste

1.3.3.7. Delete

Delete data

1.3.3.8. Tool

Tool functions include: alignment, distribution, group, combination, and conversion to curves.

When there are multiple data, the data can be aligned up, down, left, right or center.

When there are more than three data, the horizontal equal width alignment or vertical data alignment can be realized, as shown in Figure 2-47.

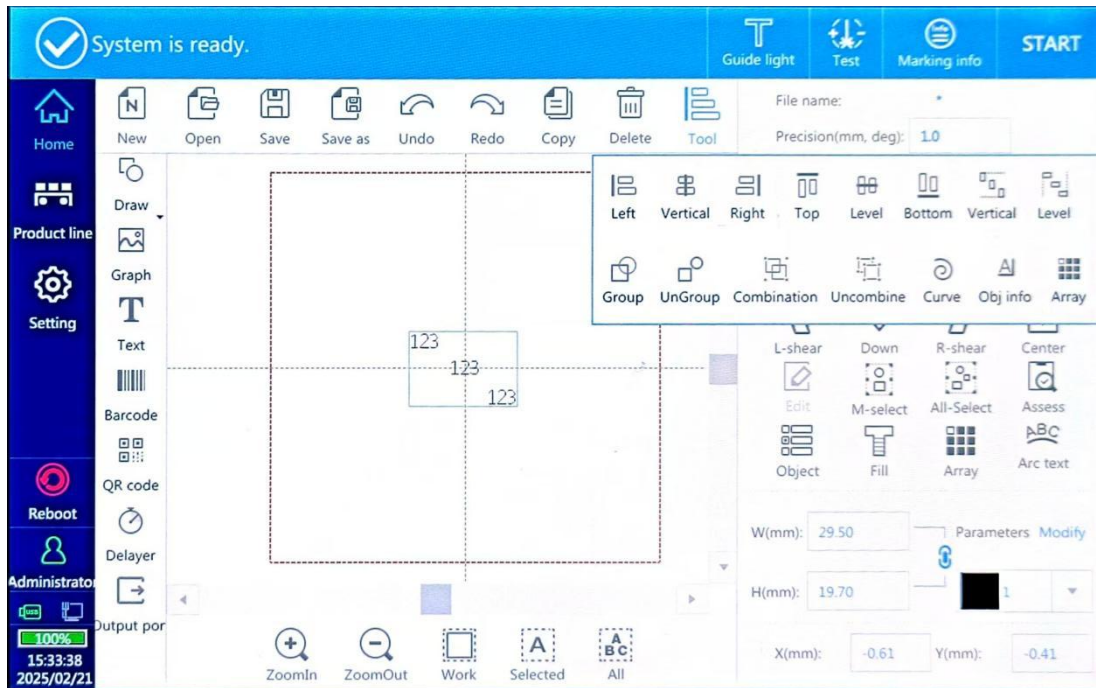

Figure 2-47

Left: align the selected objects to the left.

Vertical: To align the selected objects vertically.

Right: align the selected objects to the right.

Top: Align the top of the selected object.

Level: Aligns the selected objects horizontally.

Bottom: Aligns the selected objects below.

Vertical: distributes the selected object in the Y direction (there must be 3 or more objects).

Level: the selected object X in the horizontal equiometric distribution (objects must be 3 or more).

Group: Combine two or more items into one item

UnGroup: Reseparate the combined items

Combination: Combine the selected vector graph into a new

vector graph.

Uncombine: the vector graph or text content can be separated into a single vector graph

Curve: convert the text into a vector

Obj info: set the rotating object angle, optimize the font overlap, and remove the intersection (only N_YH 1 font supports intersection). Optimize the order of drawing marking.

Example: The optimization overlap is set to 1, and the original attribute and the setting optimization overlap attribute are compared as follows:

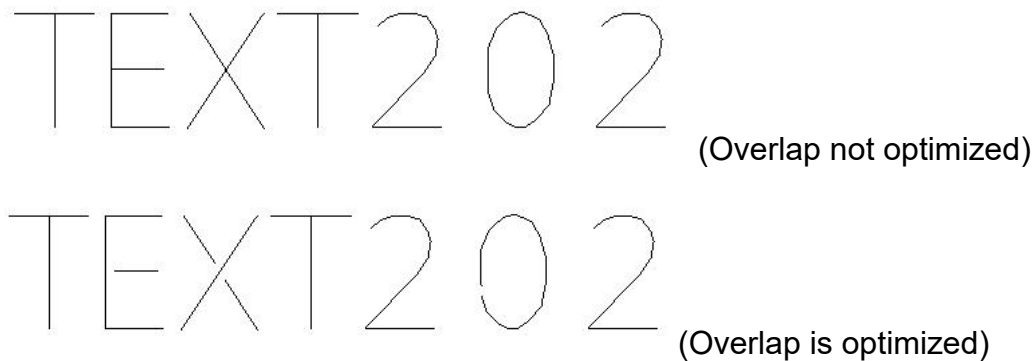

Array: Copy the selected files to multiple lines and multiple columns (support flight marking).

Array Replication

Number of columns: 2

Number of rows: 2

Column spacing (mm): 40

Line spacing (mm): 40

Direction

$\begin{matrix} 2 & 3 \\ 1 & 4 \end{matrix}$
 $\begin{matrix} 1 & 2 \\ 4 & 3 \end{matrix}$
 $\begin{matrix} 4 & 1 \\ 3 & 2 \end{matrix}$
 $\begin{matrix} 3 & 4 \\ 2 & 1 \end{matrix}$

CW ▼

OK Cancel



1.3.3.9. Object

Files that exist in the current edit box, as shown in Figure Figure 2-48.

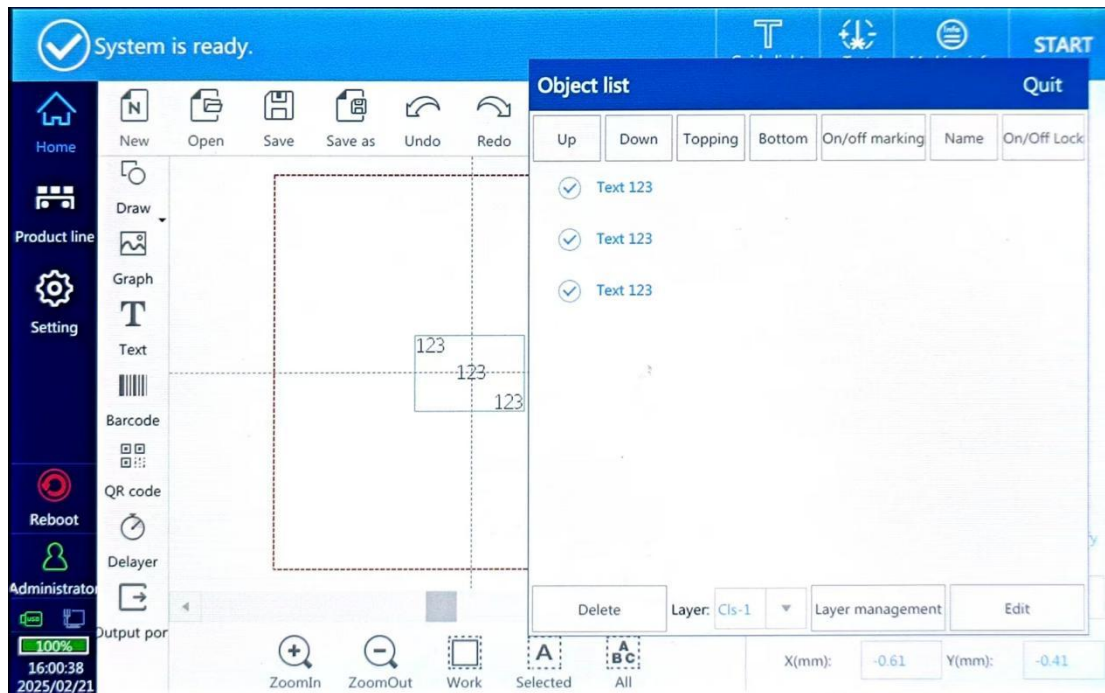

Figure 2-48

Up: move the selected items up, adjust the order of items marking, marking order from top to bottom.

Down: move the selected items down, adjust the order of the items marking, marking the order from top to bottom

Topping: Move the selected items to the top end

Bottom: Move the selected item to the bottom

On / off marking: Turn the selected item on or off

Name: Modify the selected item name

On / Off Lock: You can lock the selected items on or off

Delete: Delete the selected item

Layer: If there are three data at the same time, the order of data can be finished after the previous one, add a layer, each provision is set as a single layer, change the order of marking,

click layer management, as shown in Figure 2-49. Example:
 There are three data in the current editing box, which need to be marked one and then the next one. At this time, you need to add three layers, one serial number for each layer, and the start delay of each layer must be set a value, which can be set to 1. Click OK to return to the home page, as shown in Figure 2-50, each piece of data needs to choose a different layer serial number at the layer.

Edit: Select a single text to edit a file.

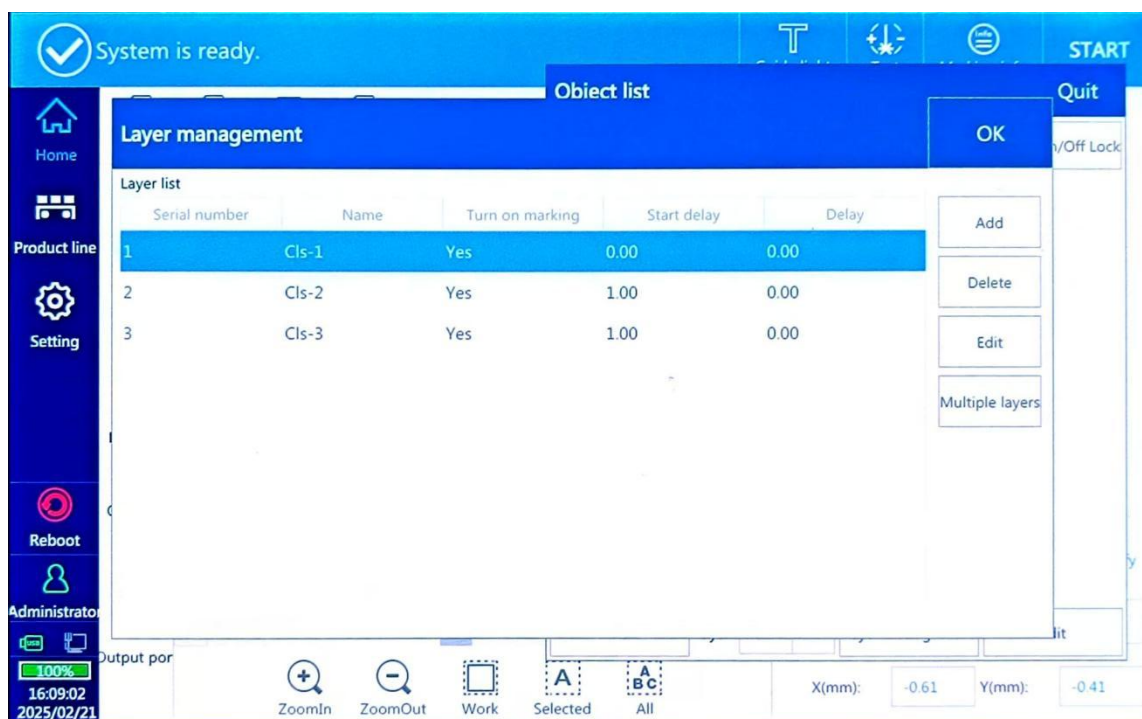

Figure 2-49

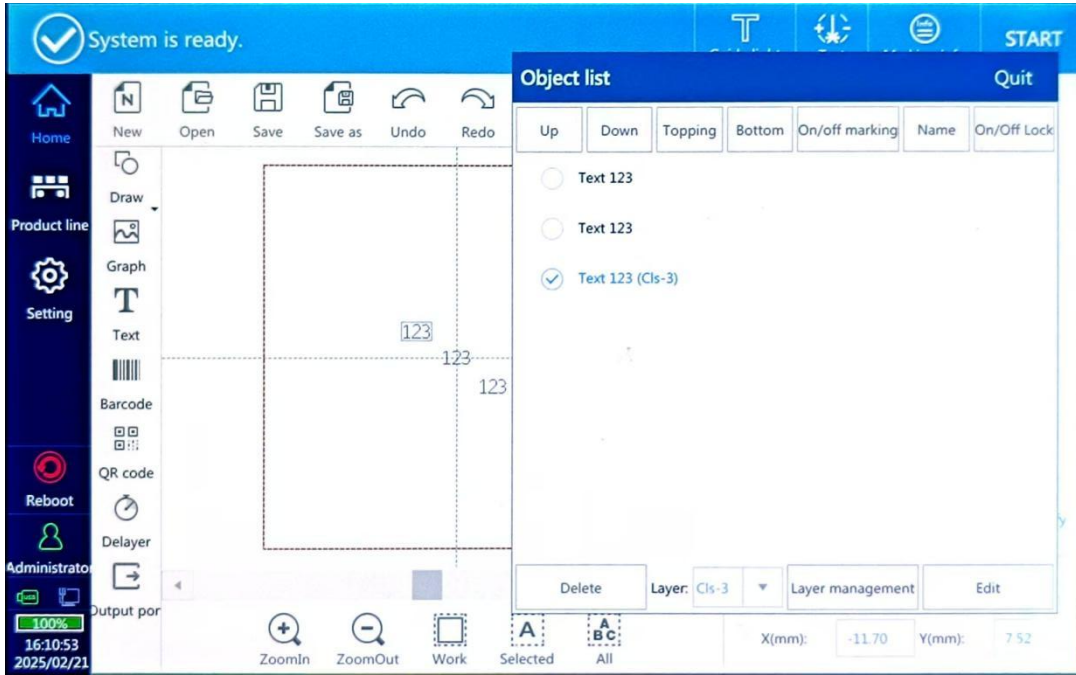
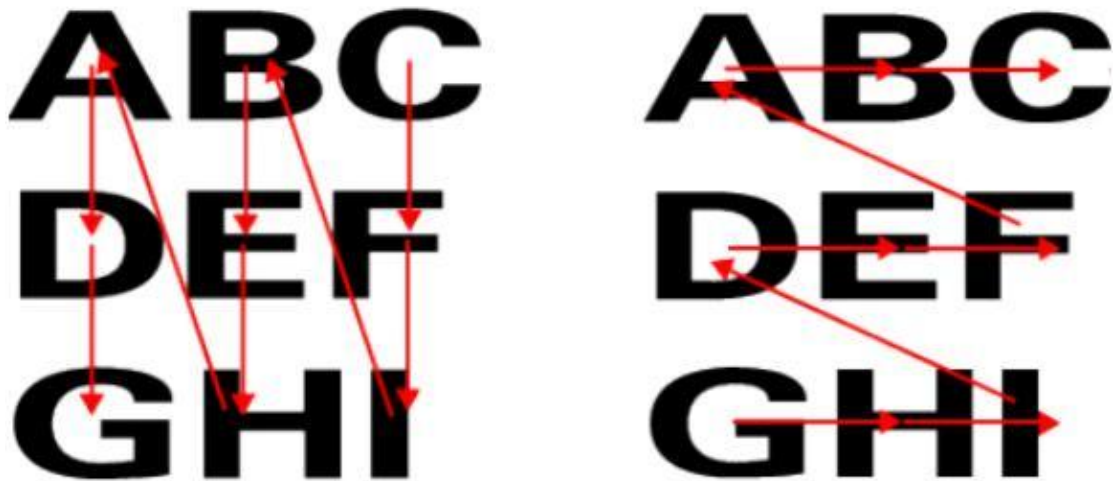

Figure 2-50

The marking order of the same layer in the left figure, and the marking order of different layers in the right figure.



1.3.3.10. Arc text

Click the arc text button to modify the current data into arc text, as shown in Figure 2-51. Click Yes, the data will become arc text.

Arc text

Arc text Yes

Reverse text order Yes

Text style 

Arc radius x(mm)

Arc radius y(mm)

Starting angle

Limit angle

Figure 2-51

Reverse text order: Text sort direction

Text style: Select as needed

Arc radius X: The radius of the curved text on the X-axis

Arc radius Y: the radius of the arc text on the Y-axis

Starting angle: the starting angle of the first character

Limit angle: the Angle range of arc circle(for example, 360-degree arc-shaped text is arc-shaped text, 180-degree arc-shaped text is semi-circular arc-shaped text, as shown in

Figure 2-52)

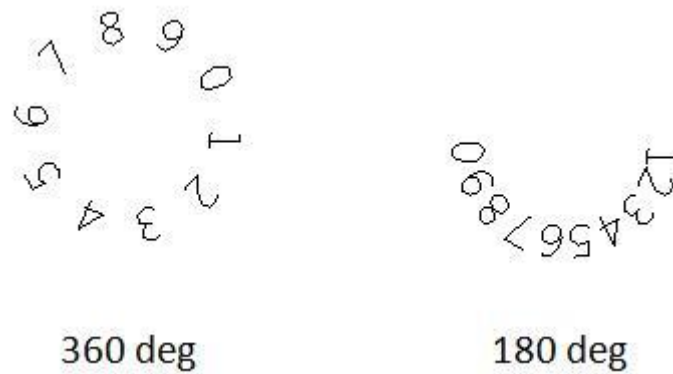

Figure 2-52

1.3.3.11. Fill

When the font is a double line, or when the picture is a head-to-end vector map, it can be filled, as shown in Figure 2-53.

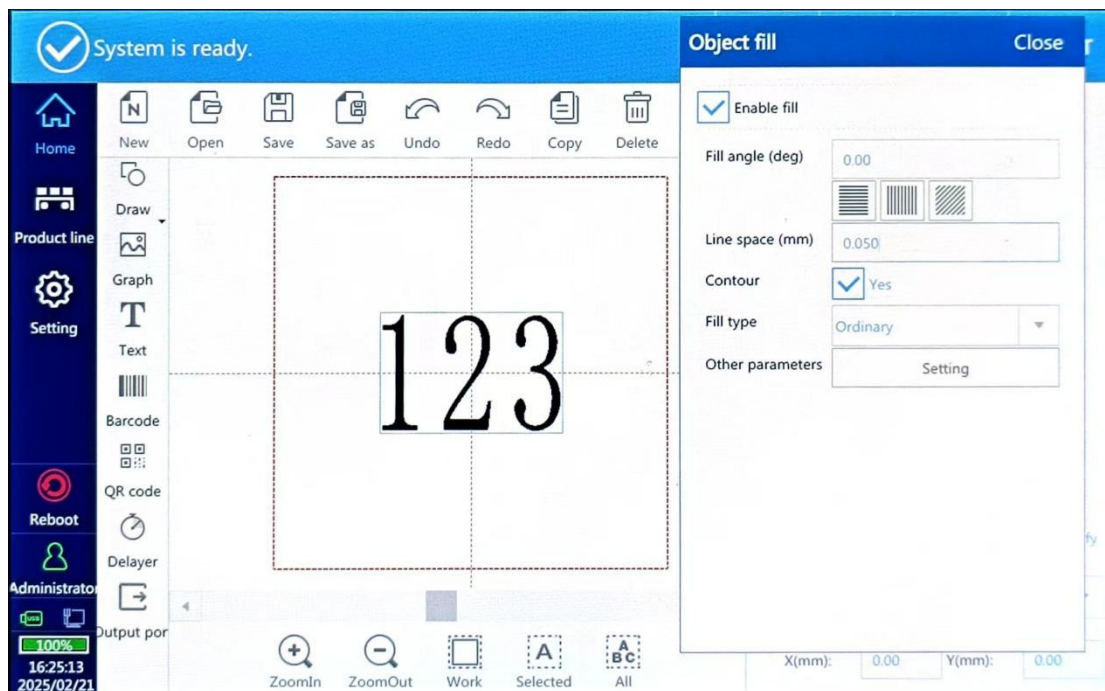

Figure 2-53

Enable fill: Selected to enable graphics or font filling

Fill angle: fill the line and X axis corner, you can choose the

figure quick fill

Line space: the distance between the filling lines

Contour: Whether to enable the frame.

Fill type: optimization (which can reduce the marking time), and mark the static marking of ordinary line filling line according to the direction of the arrow, as shown in Figure 2-54.

Arch filling: fill the line in the bow shape way.

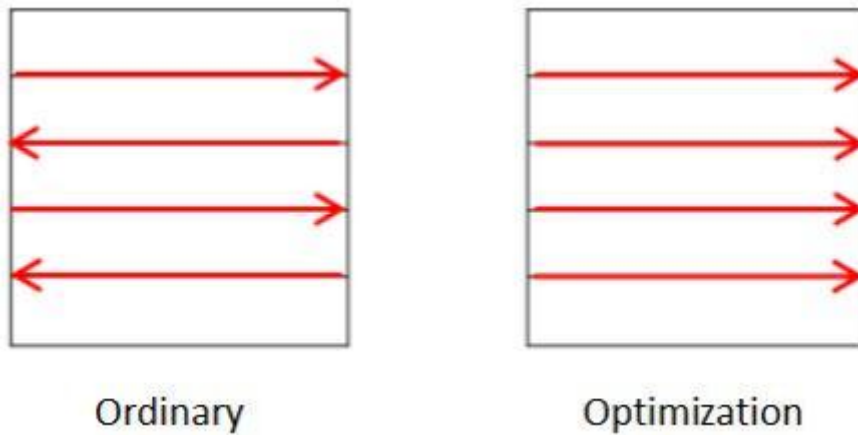

Figure 2-54

Other parameters: as shown in Figure 2-55.

Figure 2-55

Evenly distributed: Average distribution of filling line spacing

Margin: the distance between the line and the enabling frame

Straight indent: the distance between the line and the enabling frame

Boundary ring number: the number of borders

Ring spacing: the distance between border and border

Multiple fills: the number of line filling times

Every offset: the angle of last and next offset

Distribution value: Custom distribution filling line spacing

1.3.3.12. Array

Arrange objects as shown in 2-56, set the base parameters, the number of rows / column directions and the distance

between them, and set the arrangement direction. You can also fine-tune the position. Set complete click save as shown in Figure 2-57.

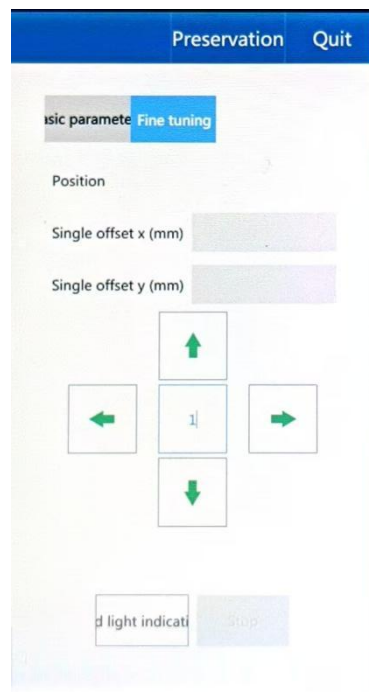
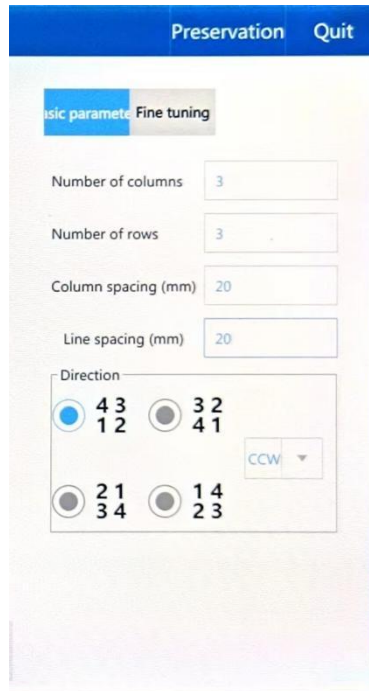

Figure 2-56

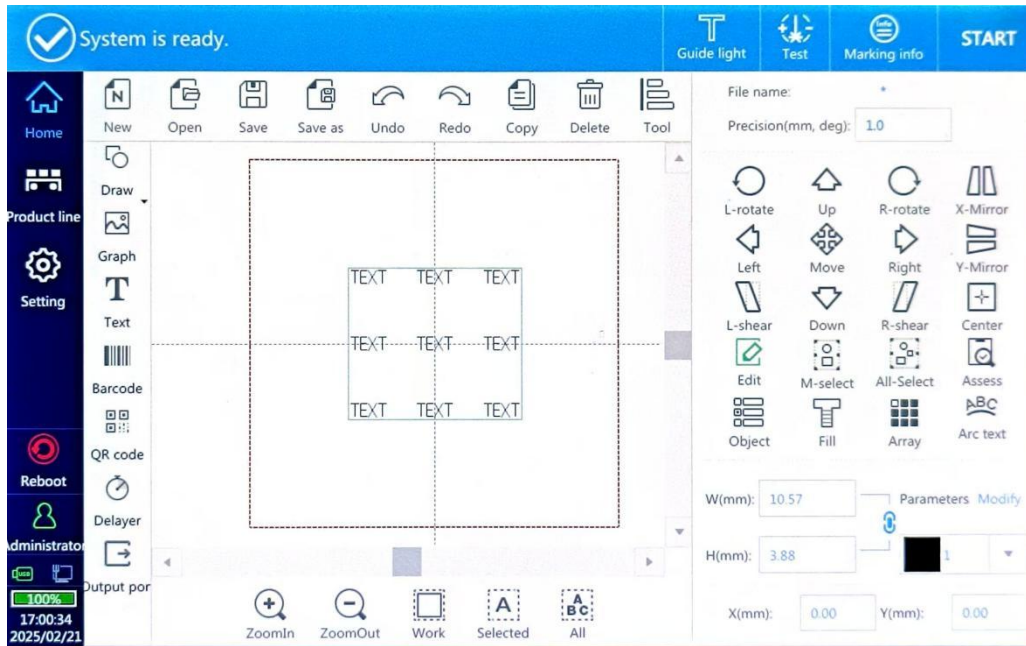



Figure 2-57

1.3.3.13. Parameters

Select the color block corresponding to the marking parameter, the marking parameter can be directly modified, can also be modified in the setting function- - - -marking parameters, different text can choose different color blocks, but also can choose the same color block.

1.3.3.14. Dimensions and coordinates

Modify the size of the text and the position of the text coordinates, as shown in Figure 2-58, and click the correlation

button . Change the width or height separately.

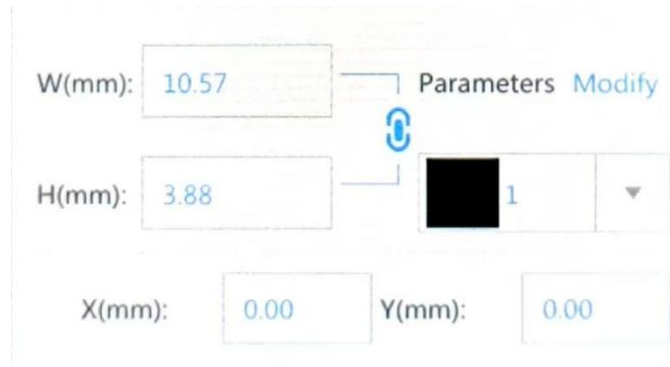
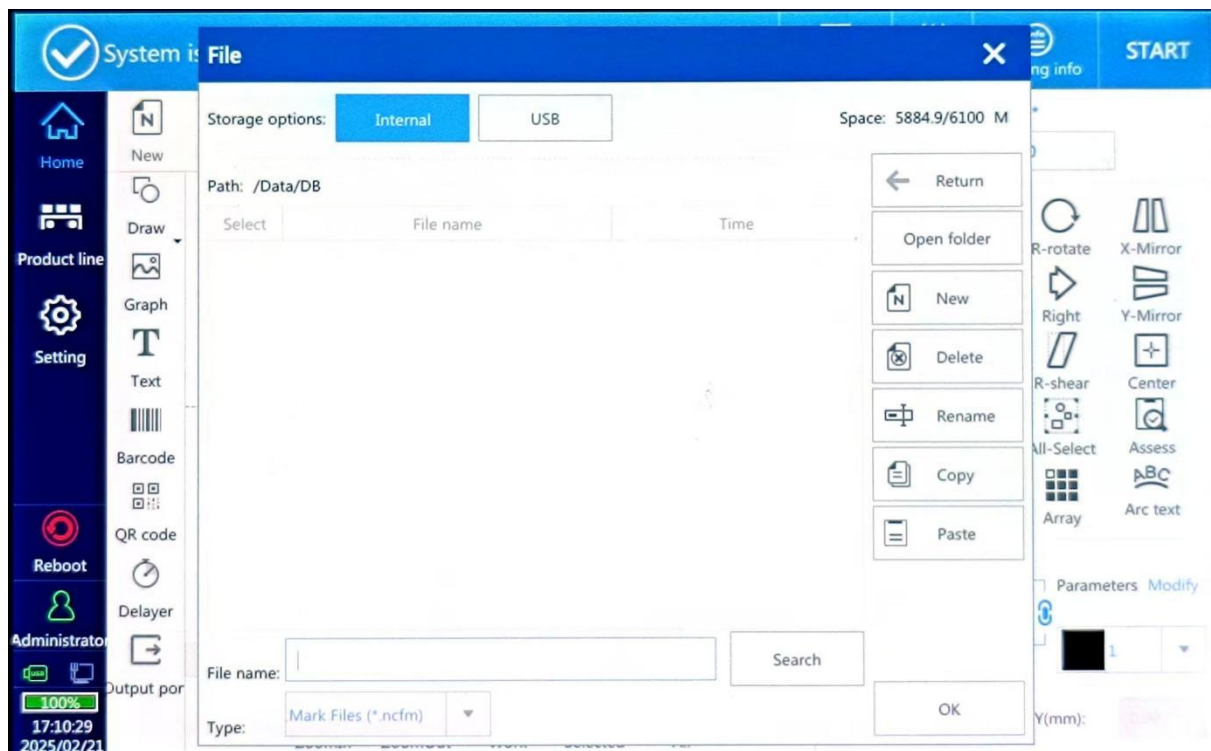

Figure 2-58

1.3.3.15. File management

Document management: manage code printing files, as shown in the figure below.



Spray code file management

You can copy the files already saved inside the system to the U disk, or copy the files in the U disk to the system.

usage method:

1. Click internal, select the file, and click Copy

2. Click USB, click paste, the system internal file is successfully copied to the U disk.

1.4. System toolbar



Document:Manage spray files

ZoomIn:Zoom tool

ZoomOut:Zoom out tool

Work:Show the entire marking area

Selected:Maximize display of selected objects

ALL:Maximize all objects

1.5. Keyboard introduction

The keyboard interface is shown in Figure 2-59.

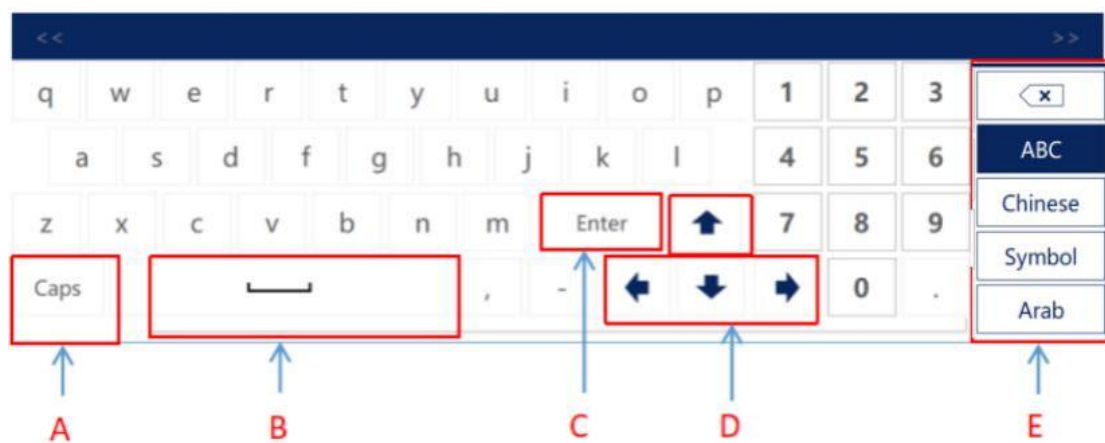

Figure 2-59

A: Case switch key

B: space bar

C: enter key

D: Move the cursor up, down ,left and right

E: Delete, input method switch, symbol (note: Chinese is pinyin input)

Setting: set the input method displayed by the keyboard. The keyboard can display up to 4 input methods at the same time.

2. Production line setting

2.1. Static spray code setting

1. Pipeline settings

The pipeline direction selects stop, as shown in Figure 3-1.

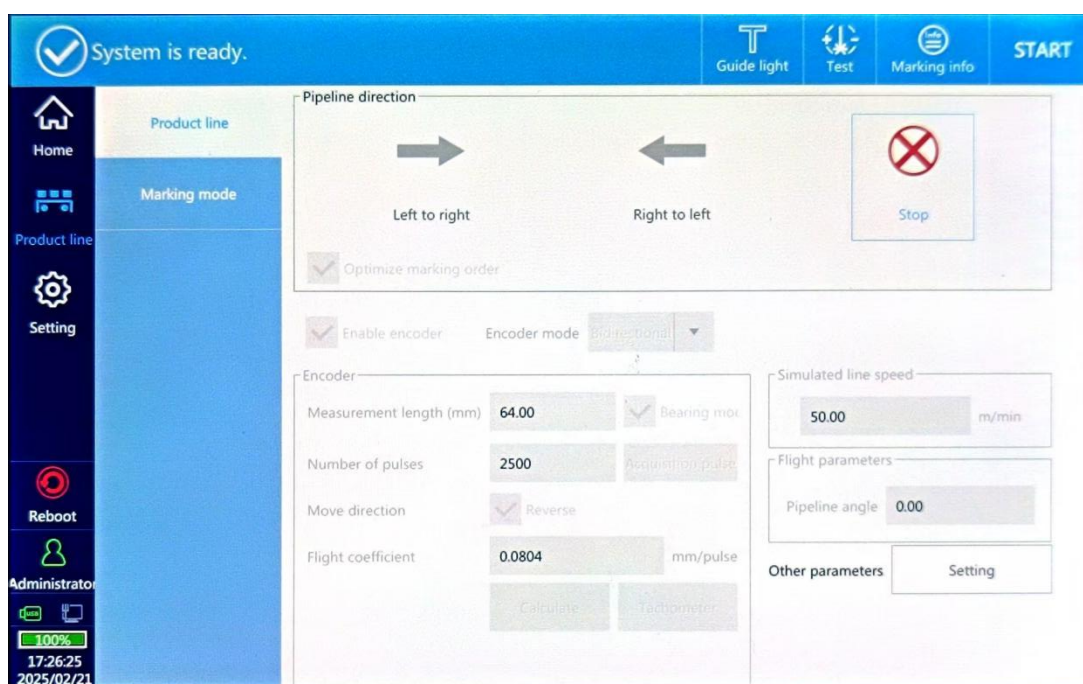

Figure 3-1

2. Marking mode setting

Marking mode can choose jog mode or sensor/foot mode.

2.1.1. Jog mode

The marking mode is changed to jog mode, as shown in Figure

3-2.

Foot Switch: When the mode is Jog mode, the foot switch can be selected as the trigger , which can set the foot filter. Click to start to spray code, wait until the foot signal to spray code.

Cont. mode: when checking, click to start spraying code according to the time interval, when not checked, click to start spraying code marking once.

Red light mode: after the marking is completed, the red light guide runs automatically.

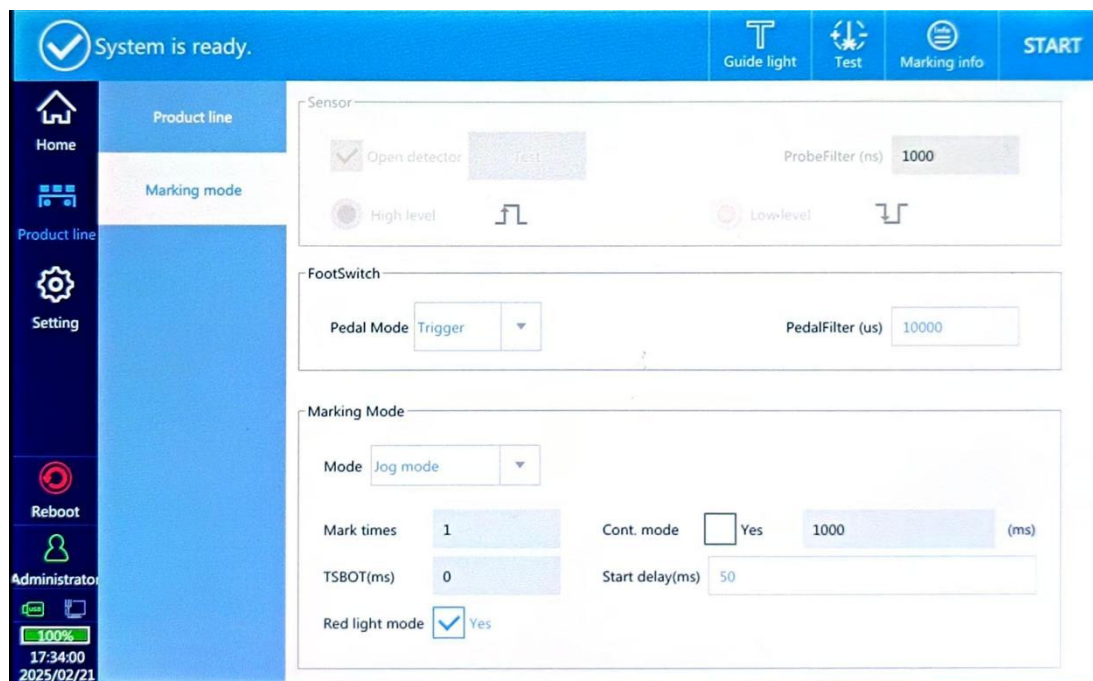

Figure 3-2

2.1.2. Sensor / Foot mode

The marking mode is changed to sensor / foot mode as shown in Figure 3-3. In this mode, the sensor must be turned on, or else the trigger signal cannot be received. In this mode, the

foot switch will not take effect.

Open sensor: must be checked, otherwise the trigger signal cannot be received without spraying code, can set the Probe Filter.

Level setting: Select the level trigger polarity (high level or low level trigger)

Mark times: after clicking the start sprays, the sensor triggers a signal and the system sprays it several times.

TSBOT: within the set time, the system will automatically shield the trigger signal received by the sensor

Start delay: How many milliseconds is the delay in laser output when pressing to start marking.

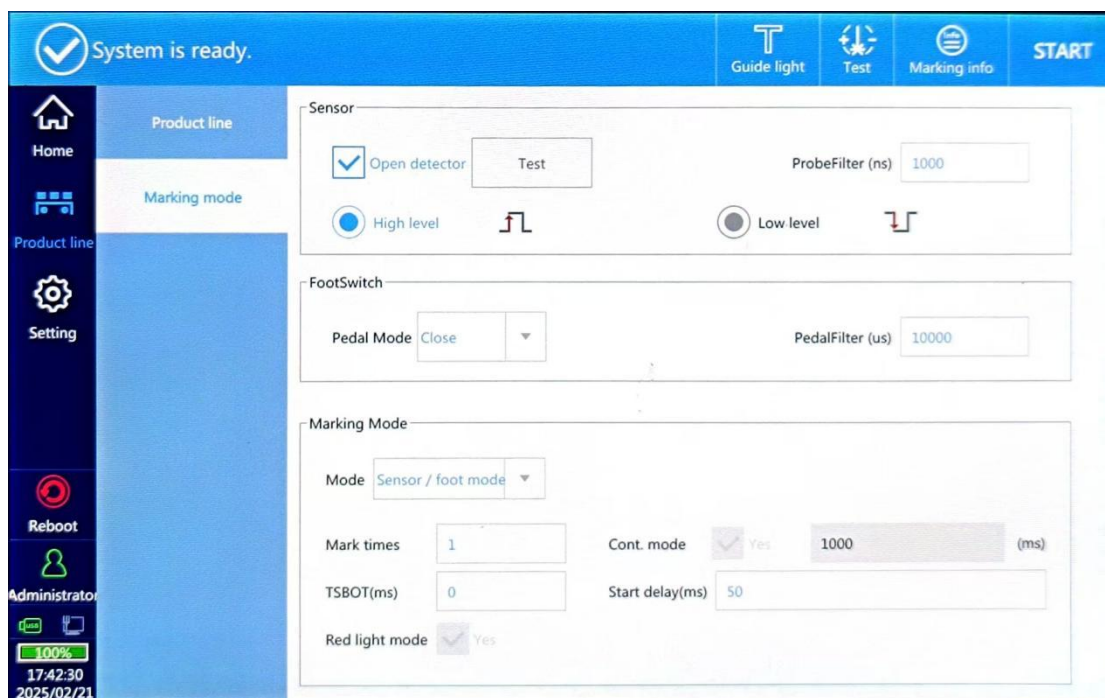

Figure 3-3

2.2. Flight marking setting

The direction of the pipeline is selected from left to right or from right to left, according to the situation of on-site coding, as shown in Figure 3-4.

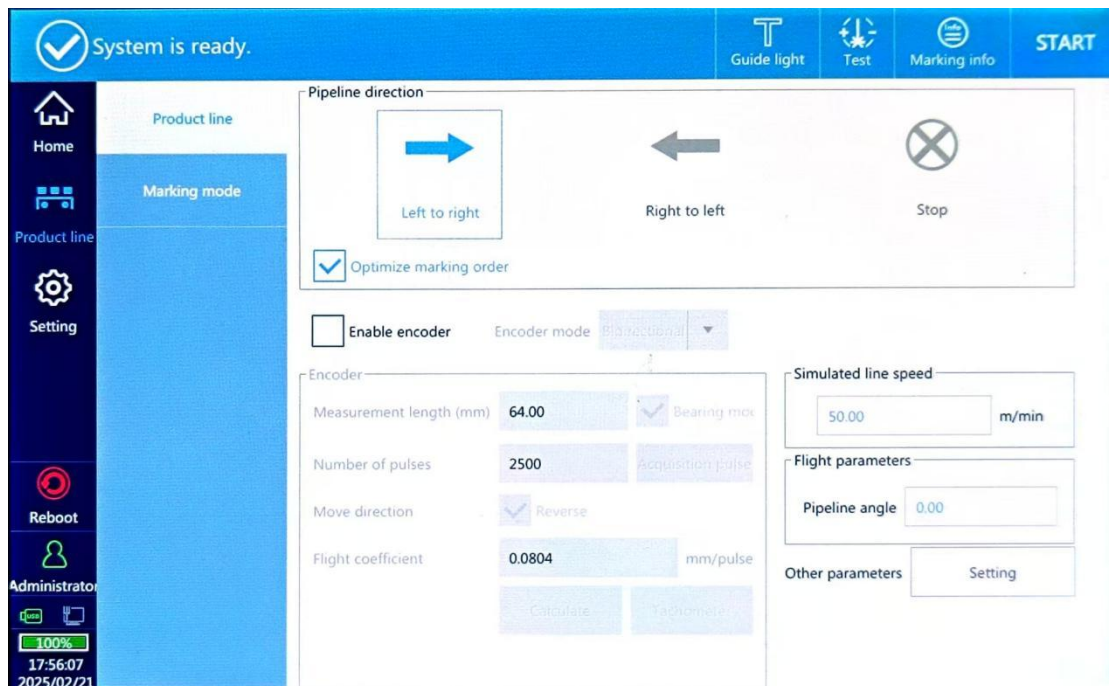
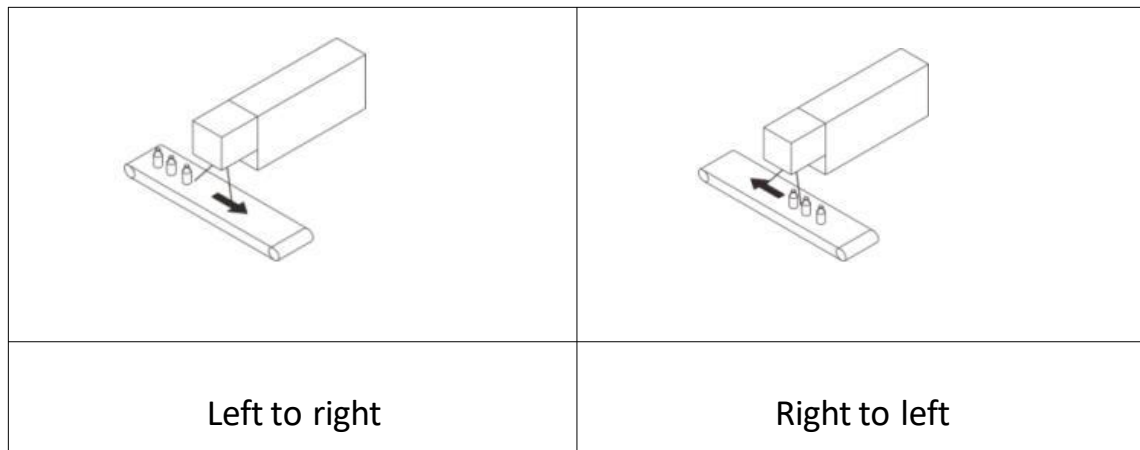
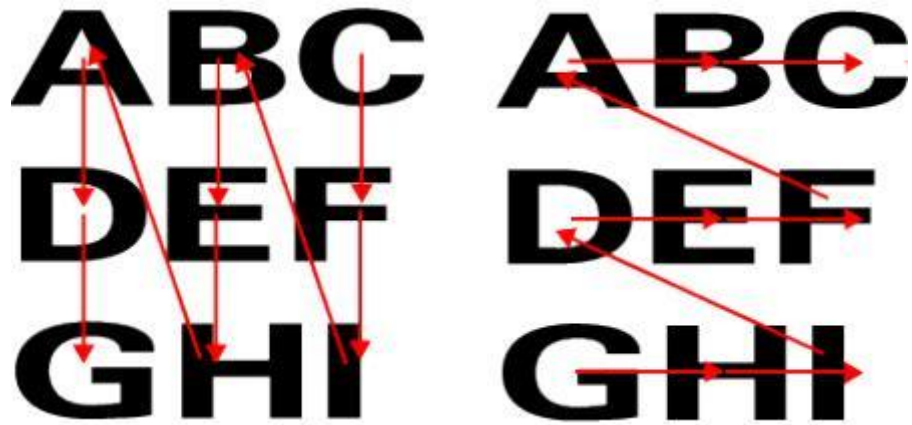

Figure 3-4

Optimize marking order: priority order (left) and no priority (right) compared as follows.



Enable encoder: when checking, use the encoder to synchronize the pipeline speed; when not checking, use the simulated pipeline speed

Encoder mode: single channel (machine selects single channel), dual channel, bidirectional

Encoder Settings:

Measurement length: The length of the wheel installed on the encoder, and the pulse number can be obtained by checking the bearing mode.

Number of pulses: The number of encoder pulses, which can be obtained from the encoder label.

Move direction: click the calculate and tachometer to automatically identify whether the reverse operation.

Flight coefficient: Click the calculate to automatically obtain the flight marking coefficient (this value is the calculated value and is fine-adjusted according to the field marking effect). The adjustment method is as follows:

Figure 1

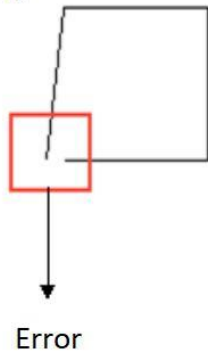

Figure 2

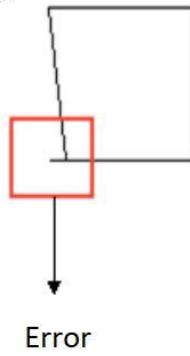
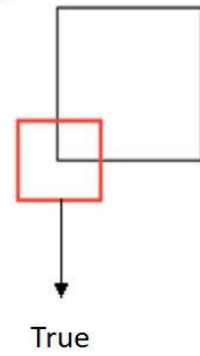

Figure 3



When Figure1 or Figure 2 occurs, the coefficient is increased or decreased according to the field laser placement direction and pipeline direction, until the marked figure is shown in Figure 3.

Pipeline Angle: the Angle between the laser and the assembly line. When there is a small Angle between the laser machine and the assembly line, and the physical adjustment is not accurate enough, the adjustment can be corrected by software modifying the Angle. The Angle diagram of the assembly line is shown in Figure 3-5.

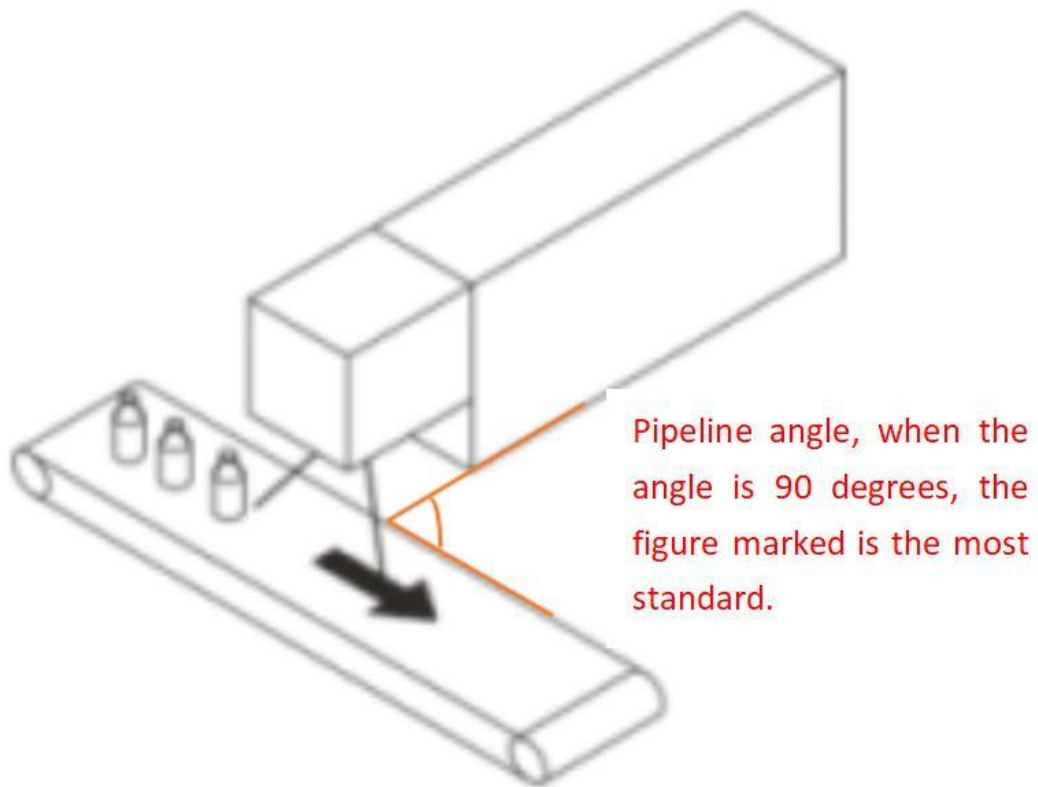

Figure 3-5

The wrong angles will occur in the following two cases, as shown in Figure Figure 3-6.

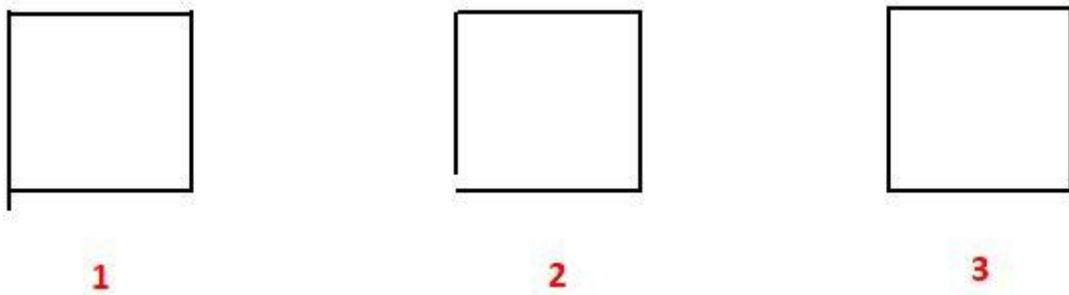

Figure 3-6

When the situation of Figure 1 or Figure 2 occurs, increase or decrease the angle of the pipeline (can be changed to a negative number) according to the direction of the laser placement on the site and the direction of the pipeline, until the marked figure is shown in Figure 3.

Other parameter : the interface is shown in Figure 3-7.

Figure 3-7

Force online update: If the current information is fixed content (excluding changed content), in order to implement online update function, the mandatory update must be selected as "Yes".

Flight compensation mode: coordinate position and Edge of the lens.

Edge distance: the starting position of the mark, which can be adjusted according to the needs.

Turn off over speed alarm: The machine will not generate an alert when the marking is too fast

Fault alarm shutdown: if the machine fails, it will shutdown

automatically, the shutdown type can be set:

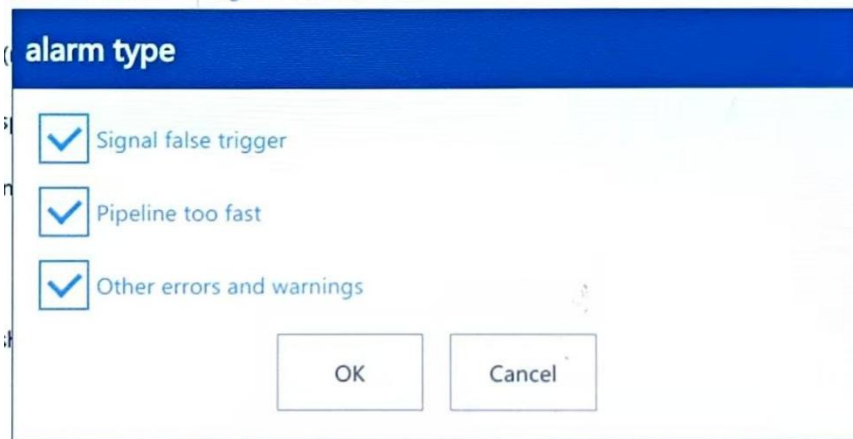

Simulated line speed

Setup method: Do not check the enable encoder, as shown in Figure 3-8. First measure the pipeline speed, and then fill the pipeline speed into the fixed speed. When the following situation occurs, the fixed speed can be modified until the mark is normal.

Figure 1

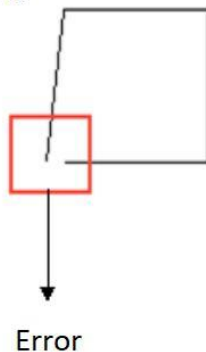

Figure 2

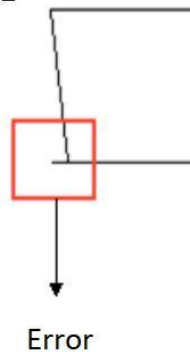
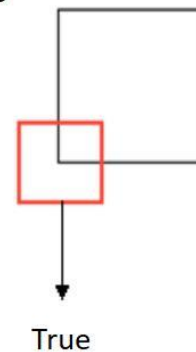

Figure 3



When the situation in Figure 1 or Figure 2 occurs, increase or decrease the simulation speed value according to the on-site laser placement direction and the pipeline direction until the marked figure is shown in Figure 3.

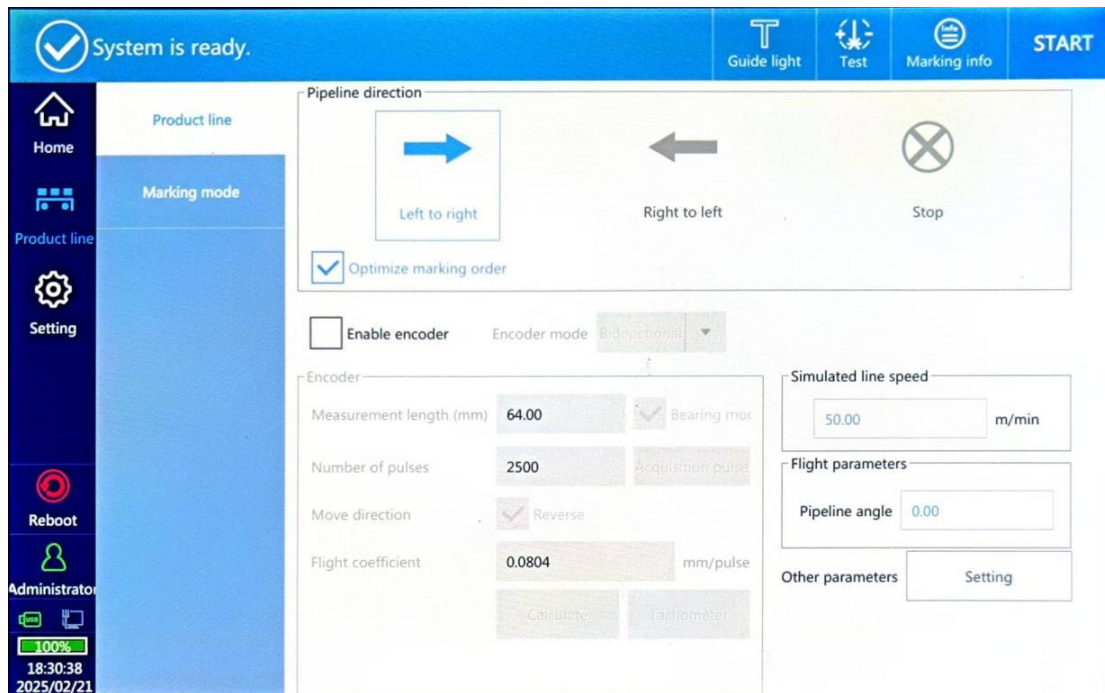

Figure 3-8

Marking mode settings

Three marking modes: normal mode, pipeline mode, and continuous mode.

2.2.1. Normal mode

The mode selects normal mode and the sensor is open, as shown in Figure 3-9.

Sensor distance: probe distance, that is, the distance between the probe installation position and the marking position

TSBOT: within the set distance, the system will automatically shield the trigger signal received by the sensor.

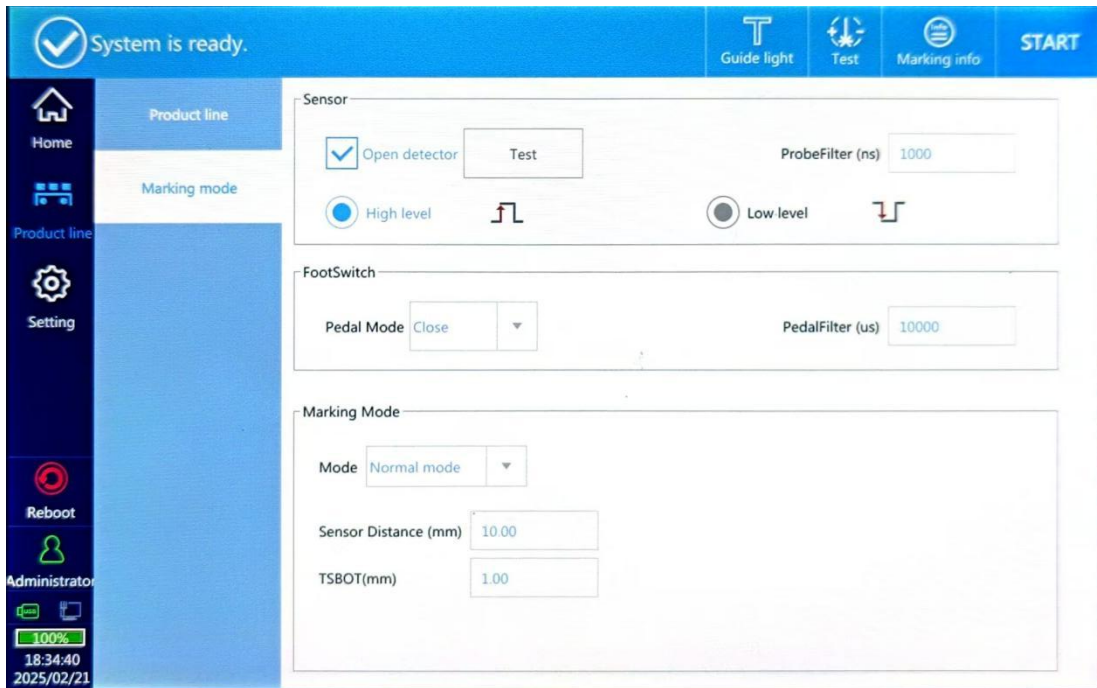

Figure 3-9

2.2.2. Pipeline mode

Marking mode select the pipeline mode, as shown in Figure 3-10.

Starting position: Starting from the moment you click to start coding, the assembly line will start coding after covering this distance.

Mark Distance: the distance between the last marking and the next marking.

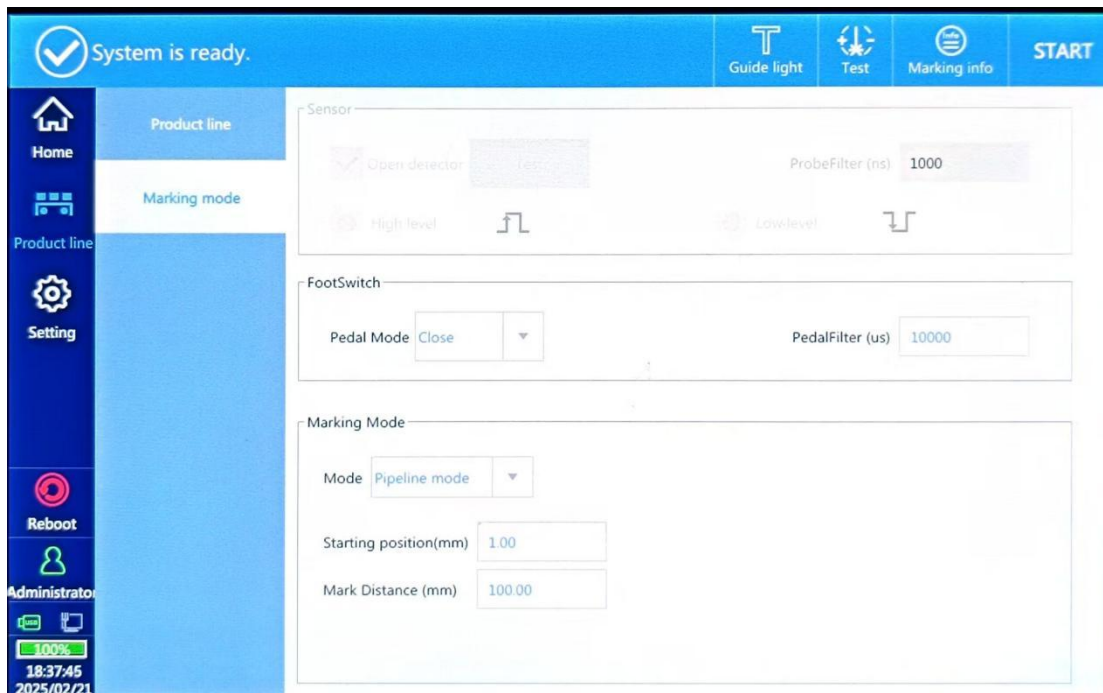

Figure 3-10

2.2.3. Continuous mode

The marking mode selects continuous mode, as shown in Figure 3-11, when the sensor must be opened and the sensor is always at high level.

Sensor distance: probe distance, that is, the distance between the probe installation position and the marking position

Mark times: Set the number of continuous coding, when there is no limit, when the sensor is at high level, the system will always code according to the set distance.

TSBOT: within the set distance, the system will automatically shield the trigger signal received by the sensor

Mark Space: the interval distance between the last marking and the next marking.

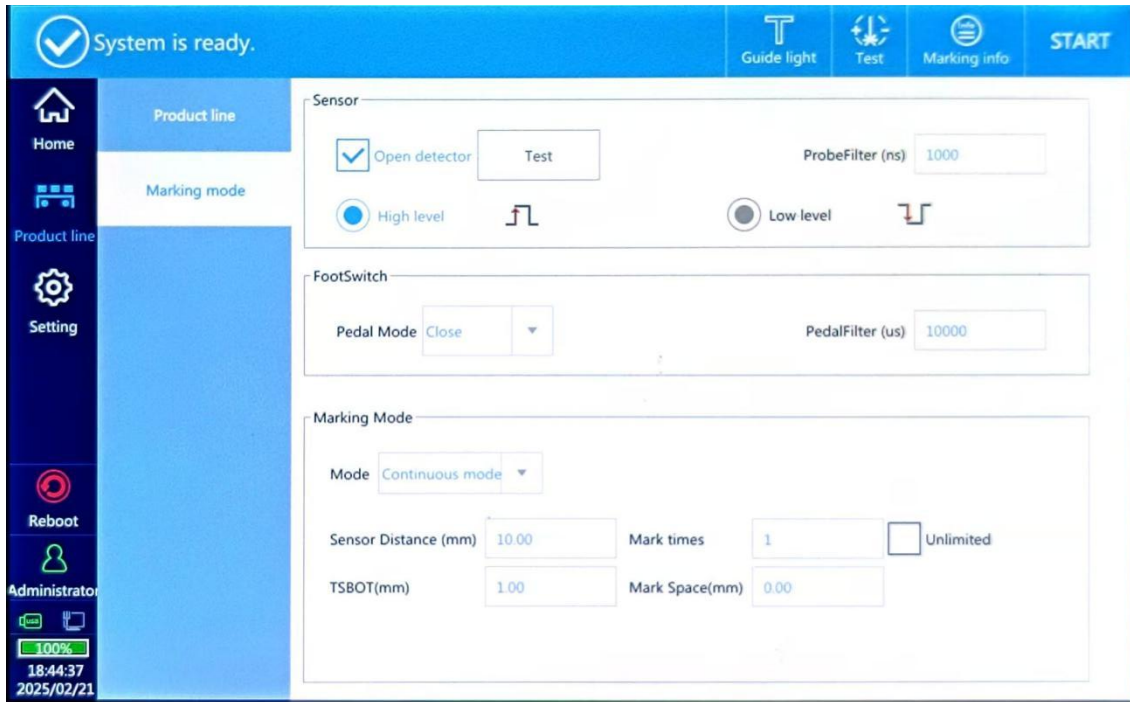

Figure 3-11

3. Setting

3.1. Marking parameters

Select the marking file on the home page, click setting-marking parameters to change the parameters of the marking data, and you can modify the default value.

Advanced: Set the advanced marking parameters.

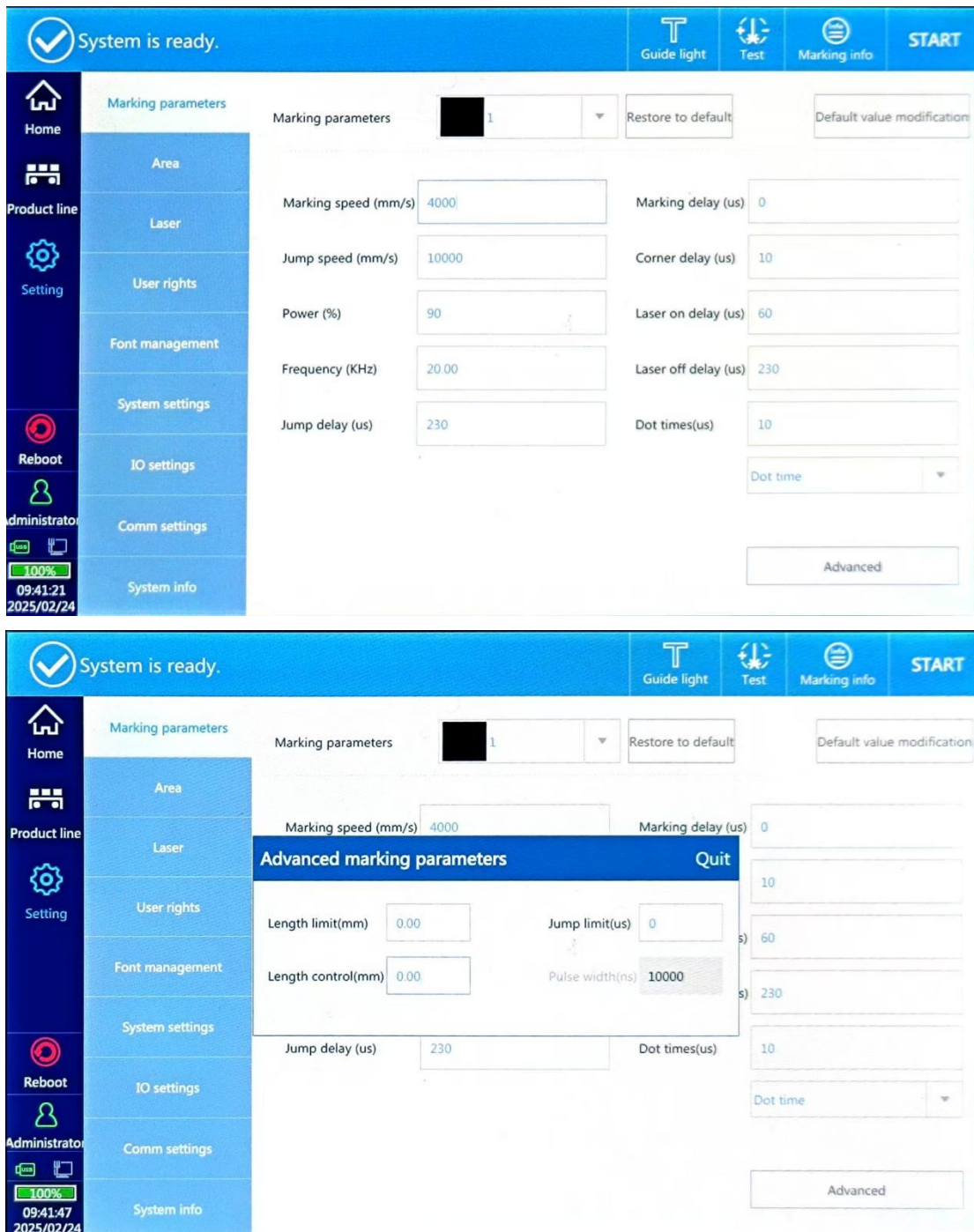

Figure 4- 1

Dot times

Single point energy, when the font is dot matrix font or add point and dot array QR code, this function is effective, can be selected as point time output or electric pulse output.

Marking speed (mm/s)

The marking speed describes the "writing" speed of the focus of the laser beam on the surface of the marking object.

Jump speed (mm/s)

The jump speed describes the speed of a vector graph after engraving, with a typical value of 2 times the mark speed.

Power (%)

The relative power of the laser (unit:%), the greater the value, the greater the power, it is recommended not to exceed 90% in use.

Frequency (KHz)

The laser frequency describes the number of pulses per unit of time, namely the number of light points per second (in KHz).

Time-lapse parameters

The delay parameters mainly include jump delay, laser on delay, laser off delay, marking delay and corner delay, delay must be adapted to the defined jump speed and marking speed. If the delay is not optimized, the quality of the marking result will decrease and the marking time will increase.

In general, the length of the on laser delay and the off laser delay had no effect on the total scan time. The on laser delay and off laser delay should be optimized first, followed by the

mark control delay, namely jump delay, mark end delay and turning point delay. It is very useful to set the jump delay and the mark end delay for a large value.

Here we will illustrate the effect of various marking delay on the quality of marking:

The jump delay is too short

If the jump delay is too short, after the jump, the scanning head is not positioned, the first marking vector has already started, and the oscillation effect will be shown as shown in Figure 4-2.

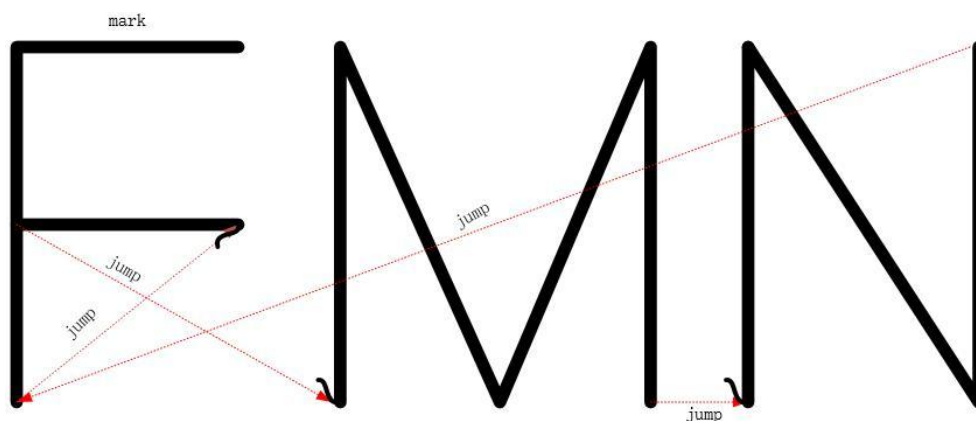

Figure 4-2

The jump delay is too long

If the jump delay is too long, there is no obvious effect. But the marking time is longer.

The time delay of opening light is too short

If the light delay is too short, the laser is on at the beginning of the marking vector, even if the lens has not reached the desired angular speed, the starting point of the respective

vector is coking, as shown in Figure 4-3.

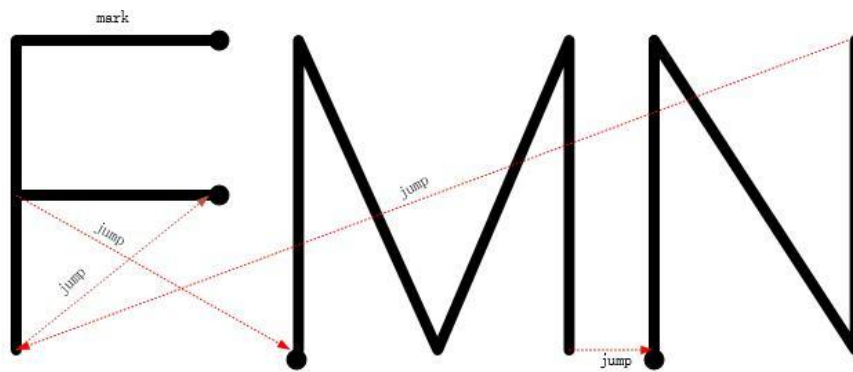

Figure 4-3

The opening time is too long

If the laser delay is too long, the laser is opened too late at the beginning of the marking vector. The starting point of the vector is not marked, as shown in Figure 4 – 4.

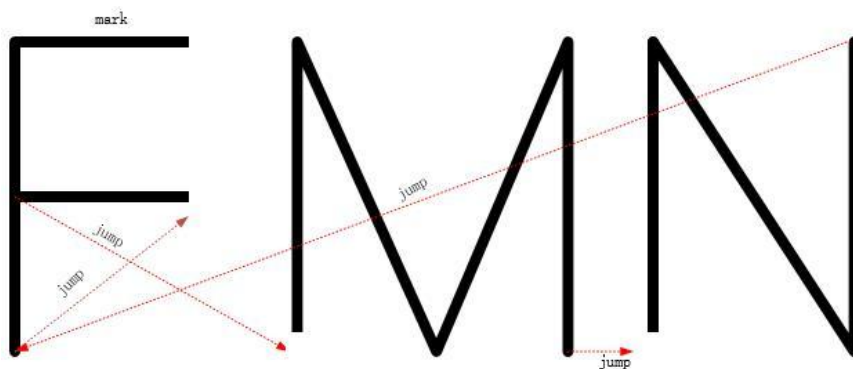

Figure 4 – 4

The time-lapse is too short

If the turn-off laser delay is too short, although the lens has not reached the final position of the vector, the laser is turned off after the final marking command of a straight line or broken line, resulting in the respective vector is not fully marked, as shown in Figure 4-5.

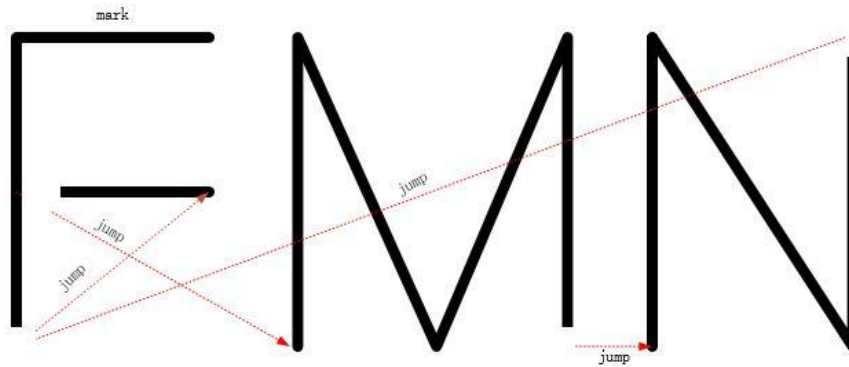

Figure 4-5

The time-lapse is too long

If the turn-off laser delay is too long, the laser is closed too late after the last mark of the line or broken line, and the laser is still open, even if the lens has stopped or moved very slowly, as a result, the end of each vector is coking. As shown in Figure Figure 4 – 6.

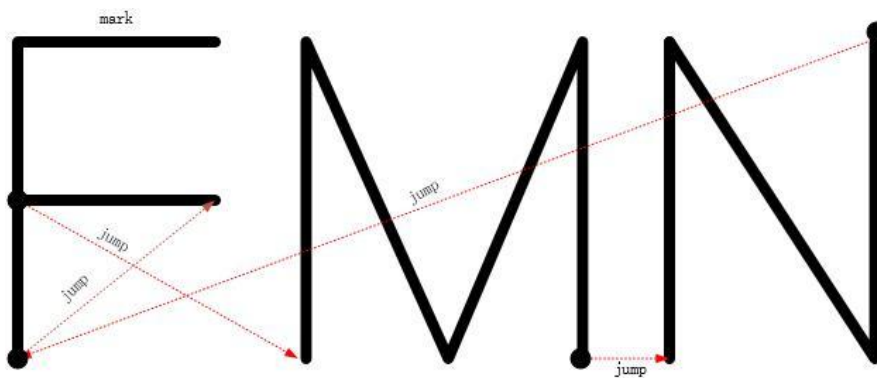

Figure 4 – 6

Marking delay

There is no significant change, but the larger the value, the longer the marking time.

The corner delay is too short

If the turning point delay is too short, the marking order on the

subsequent broken line is already executed, but the scope has not reached the end of the previous marking vector, which will lead to an arc around the corner, as shown in Figure 4-7.

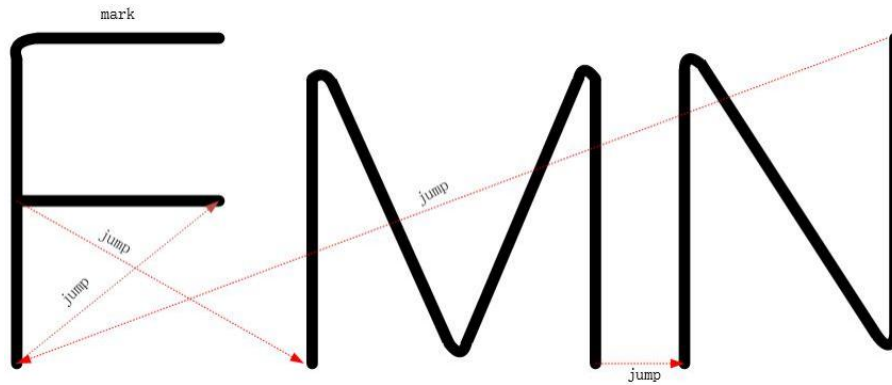

Figure 4-7

The corner delay is too long

The turning point delay is too long, and the lens moves too slowly or even stops during the subsequent marking command. Since the laser is not closed between these vectors, the coking phenomenon will occur as shown in Figure 4-8.

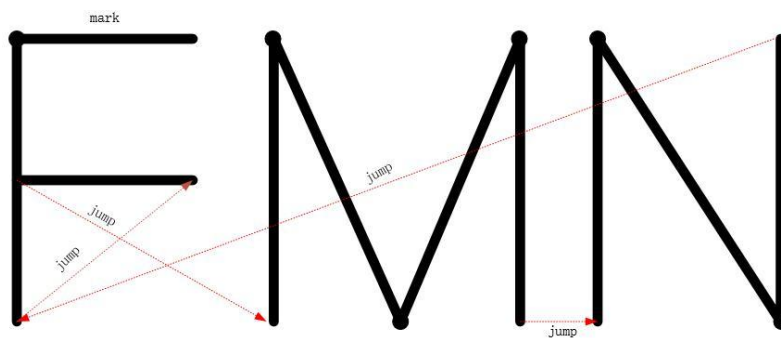

Figure 4-8

3.2. Area

3.2.1. The vibration mirror calibration

Area size: the marking range of the current field mirror

Edit region: You can set the area area display range

Mirror 1 =X, lens 2 =X: select lens 1 = X, click manual trigger, when the marked figure ABC is horizontal, the selection is correct, when the marked ABC is vertical, the selection is error, then select mirror 2 = X.

Correction: According to the field situation, observe whether the marked ABC is reversed, rotate, select the opposite mirror in reverse, until the marked content is what you need.

Coefficient correction methods are shown in the table below

First debug parameter selection automatic creation, then click test parameters to set the rectangle size. Example: If the area size is 110, the rectangular size is set 109, and then click manual trigger.

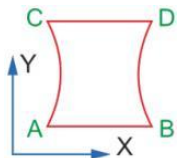
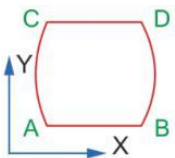
Pincushion	
	
<p>Reducing the X or Y axis corresponds to the oscillator coefficient</p>	<p>Increase the vibration coefficient corresponding to the X or Y axis</p>

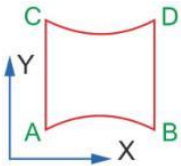
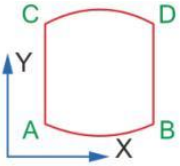
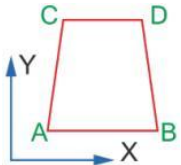
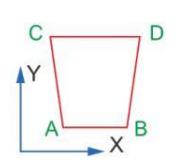
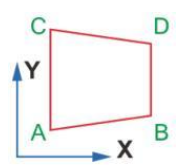
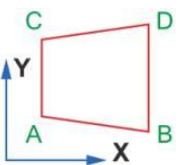
	
<p>Reducing the X or Y axis corresponds to the oscillator coefficient</p>	<p>Increase the vibration coefficient corresponding to the X or Y axis</p>
<p>Trapezoidal</p>	
	
<p>Reducing the X or Y axis corresponds to the oscillator coefficient</p>	<p>Increase the vibration coefficient corresponding to the X or Y axis</p>
	
<p>Reducing the X or Y axis corresponds to the oscillator coefficient</p>	<p>Increase the vibration coefficient corresponding to the X or Y axis</p>

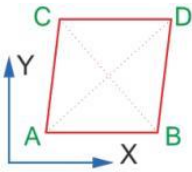
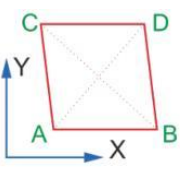
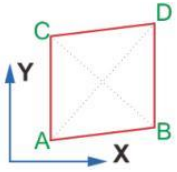
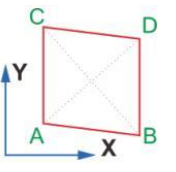
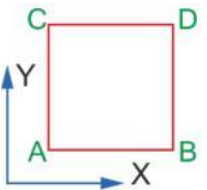
Miscut	
	
Reducing the X or Y axis corresponds to the oscillator coefficient	Increase the vibration coefficient corresponding to the X or Y axis
	
Reducing the X or Y axis corresponds to the oscillator coefficient	Increase the vibration coefficient corresponding to the X or Y axis
Proportional	
	
<p>Measure the actual frame length, and then fill in the coefficient obtained by dividing the set length by the length carved by the actual mark (note: the coefficient can not be greater than 1, if set 109 range, the mark is only 100, indicating that the maximum area range can only be marked 100, and then the area range can be changed to 100)</p>	

3.2.2. Forced light

Forced light out can test whether the laser light out is normal, this function also can be used for optical path calibration, as shown in Figure.



The image shows a software dialog box titled "Forced light". The dialog has a blue header bar with the text "Forced light" on the left and "Quit" on the right. Below the header, there are three input fields. The first is labeled "Power(%)" and contains the value "1". The second is labeled "Frequency (KHz)" and contains the value "20". The third is labeled "Time (s)" and contains the value "-1". At the bottom of the dialog, there are two buttons: "Forced light" and "Close".

3.2.3. Red light guide calibration

Click the guide light to enter the red light guide calibration interface, as shown in Figure 4-9.

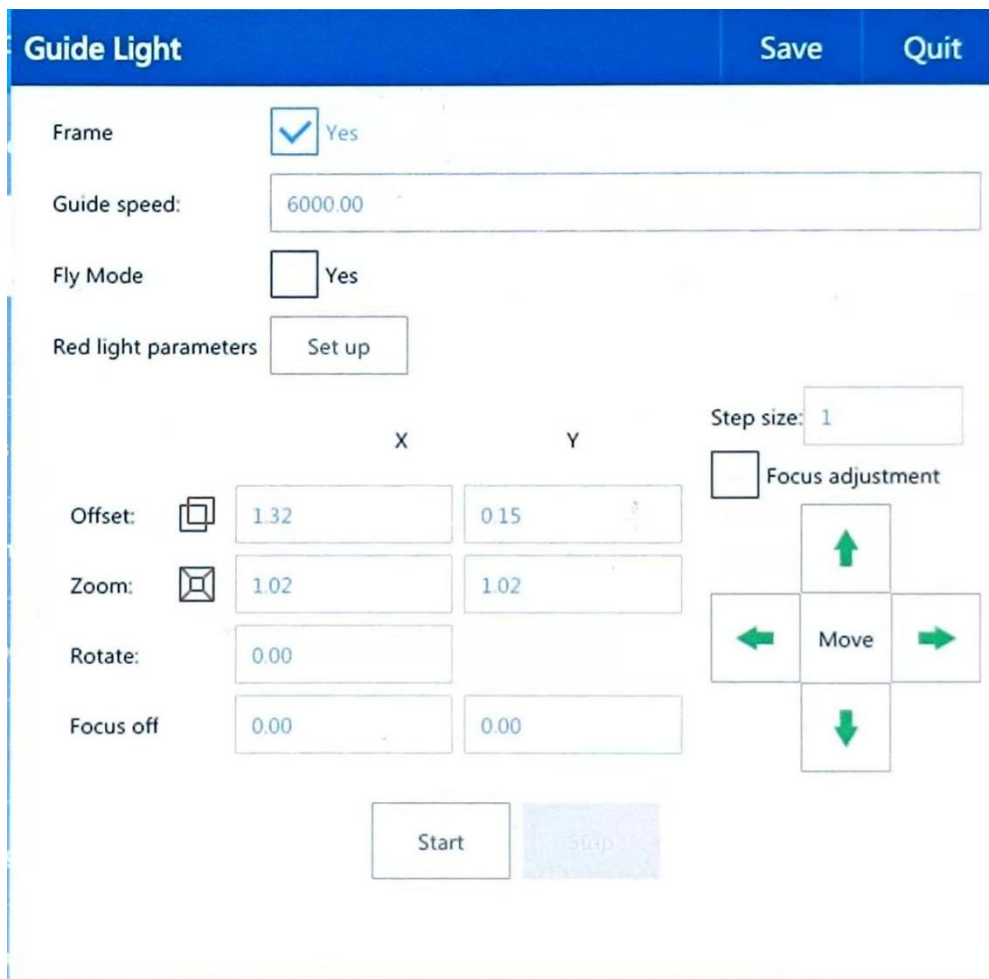

Figure 4-9

Frame: When "Yes" is selected, it is guided by a rectangle; when it is not selected, it is guided by the full path of the glyph.

Guide speed: Guide the red light line speed.

Flight Mode: red light guide into a vertical line, guide the position of the vertical line is the starting position of the flight marking, convenient to set the value of the starting distance.

Red light parameter : set the parameters of the red light guide, as shown in the figure below.

Red light parameters

Turn off red light control Yes

Use full preview Yes

Frequency (kHz)

Jump speed (mm / s)

Jump delay (US)

Corner delay (US)

On delay (US)

Light off delay (US)

The red light calibration method is as follows:

1. Add a rectangle to mark it.
2. Click the red light guide, adjust the offset, zoom and so that the red light light and the mark completely coincide.

The red light focus method is as follows:

1. Red light focus must be two red lights, one fixed and one adjustable red light.
2. the red light focus adjustment tick, adjust the up and down the left and right four buttons to make the two red light completely coincide.

3.3. Laser

Select the laser type and modify the laser parameters, the

interface is shown in Figure 4-11.

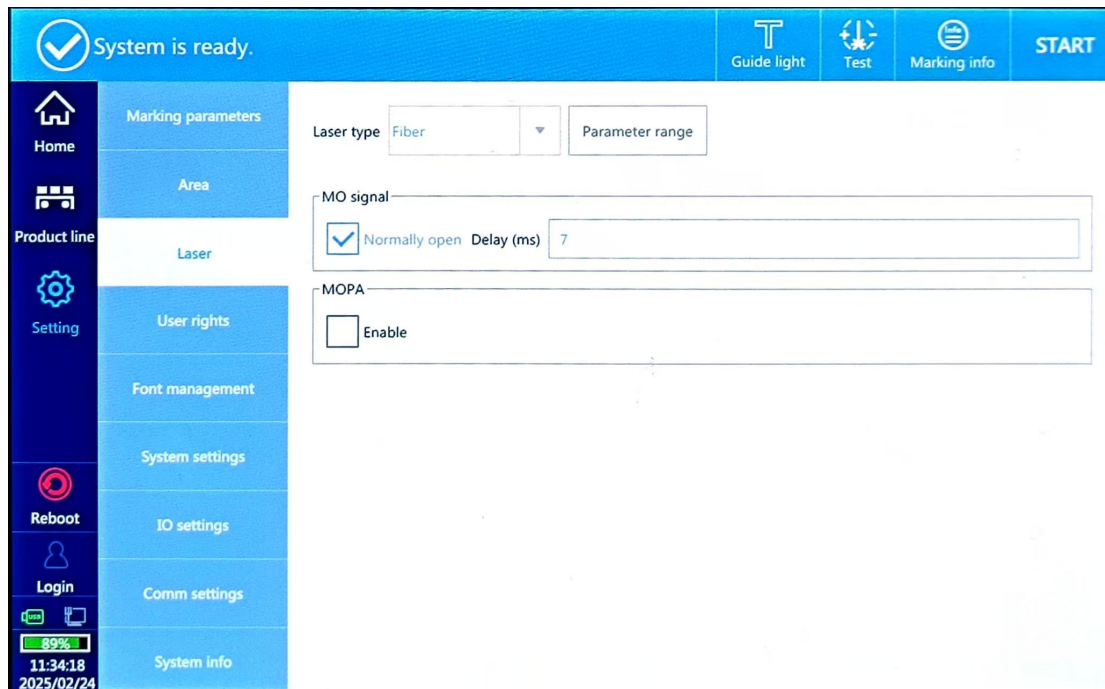

Figure 4-11

Laser type: select the type of laser, if the laser is Fiber, select Fiber and restart the system.

Parameter range: Modify the range value of the laser power and frequency.

Fiber laser properties: the interface is shown in Figure 4-12.

MO signal: can choose often open or not open, usually MO needs to be opened.

MOPA: If the laser is a MOPA structure laser, the MOPA needs to be turned on.

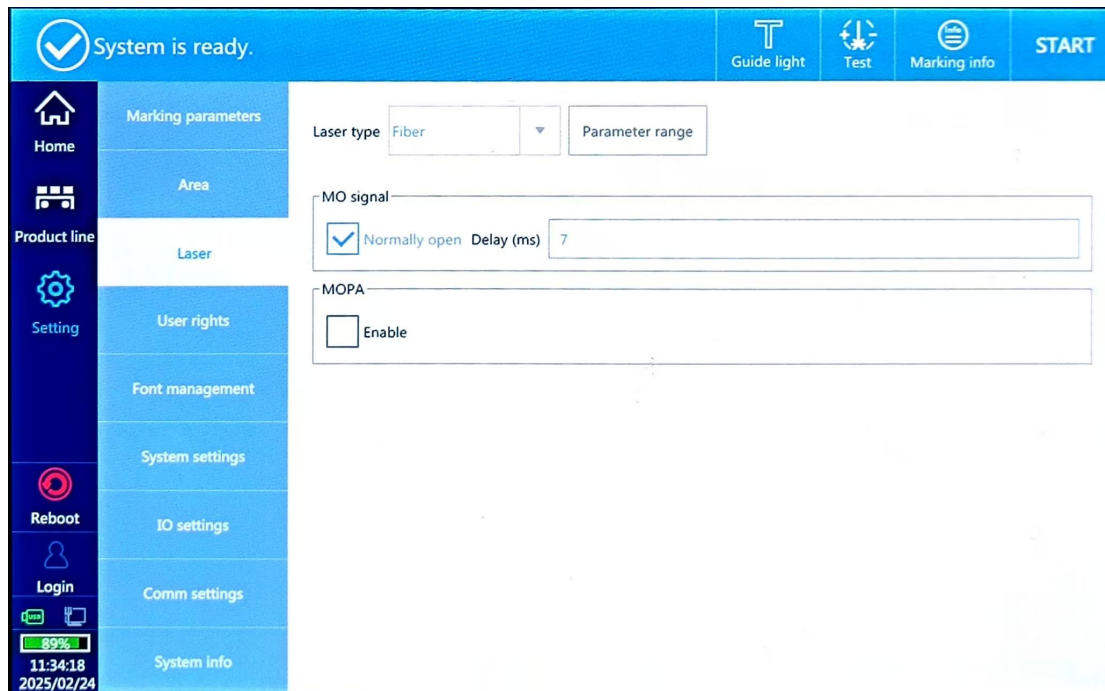

Figure 4-12

3.4. User Rights

Set the user permission and password at different level, as shown in Figure 4-16. Log in to the administrator user (password: 123) and set the usage permission and password for each user. Example: modify the Level 1 user password to 888, as shown in Figure 4-17, set the usage permission of the user, cancel the three functions of adding object, editing object and file operation, as shown in Figure 4-18. Exit the administrator user and log in to the Level1 user, the shielding function of the user has become gray and cannot be used, as shown in Figure 4-19.

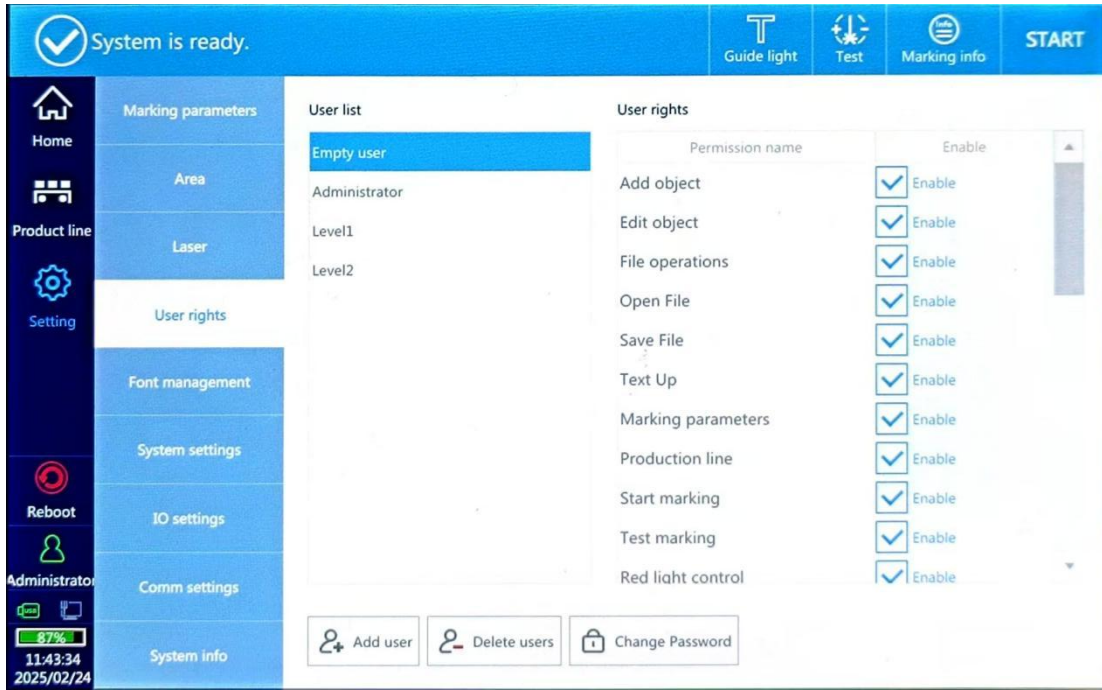

Figure 4-16



Figure 4-17

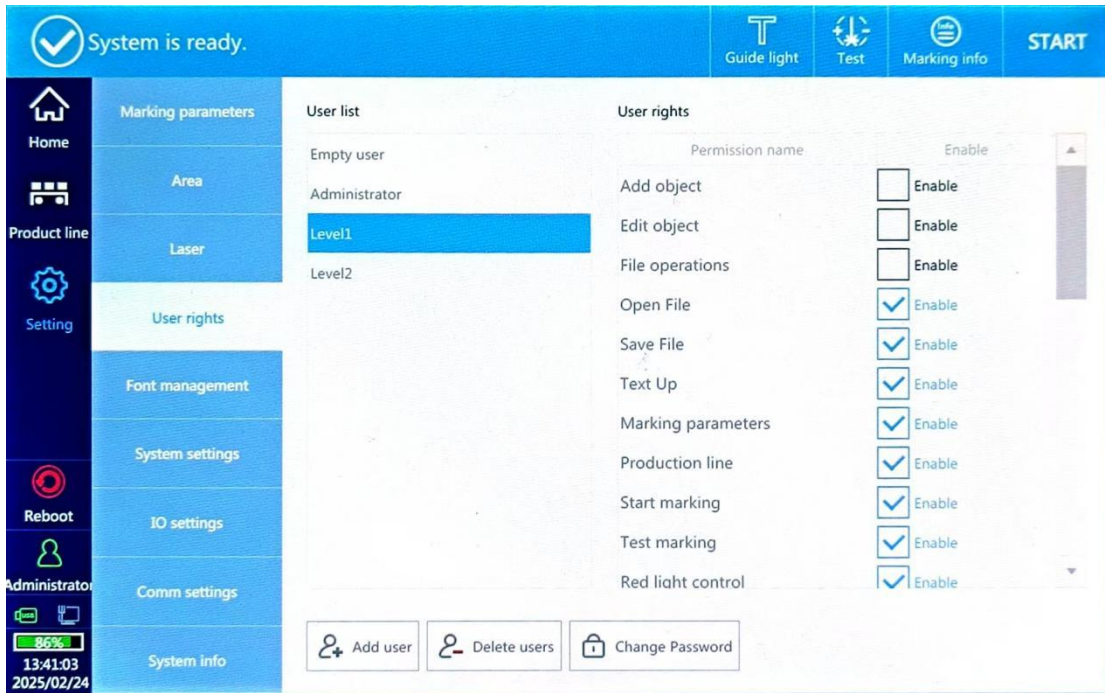

Figure 4-18

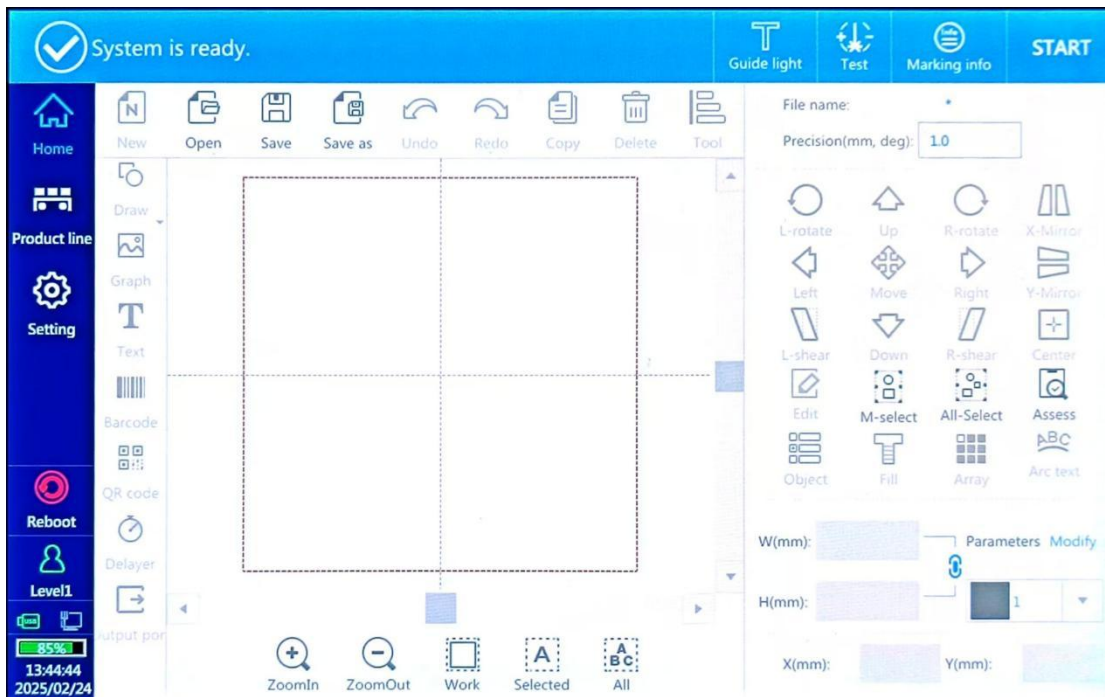
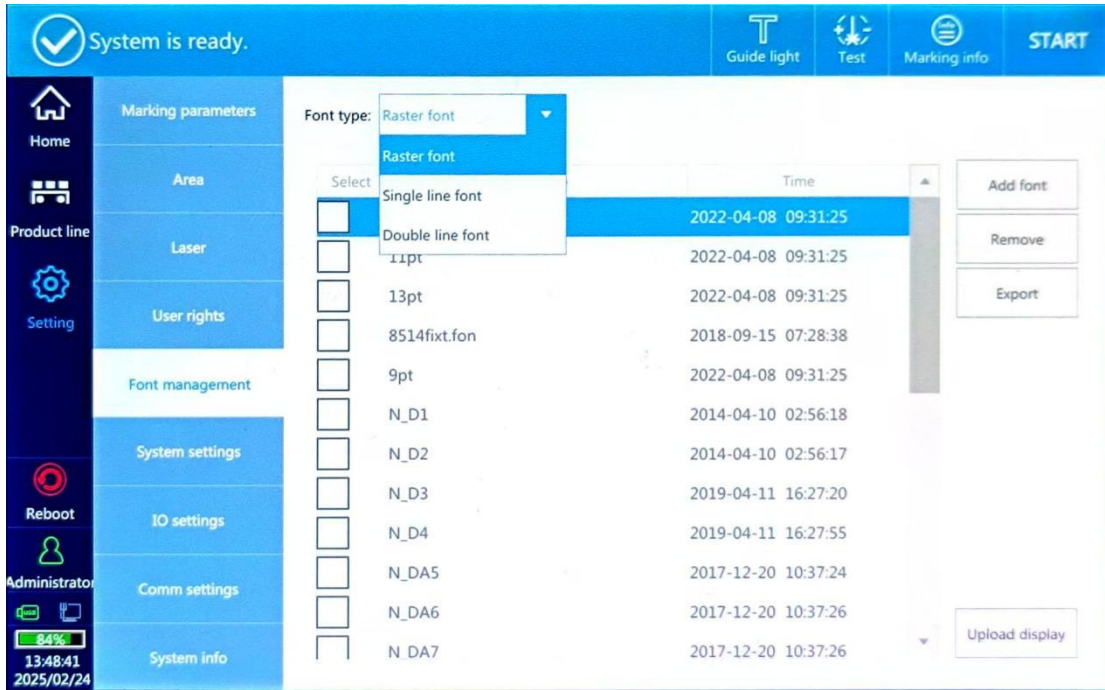

Figure 4-19

3.5. Font management

Manage fonts in the system: Add fonts, remove fonts, and export fonts.



3.6. System settings

As shown in Figure 4 - 20.

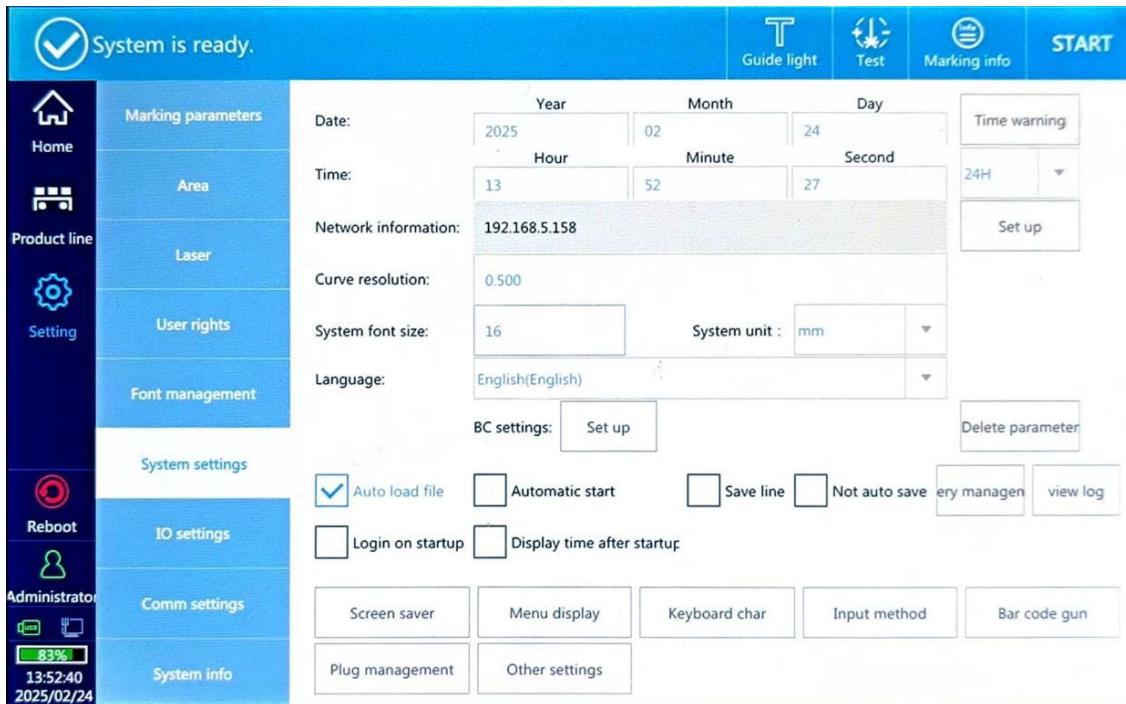

Figure 4 -20

System Settings:

Date: Set the system date

Time: Set the system time

Network information: set the DHCP information of the motherboard, click Set up, pop up interface, as shown in Figure 4-21, click enable to set the network information, can also set the machine to connect to the wired network or wireless network, and then click to save.

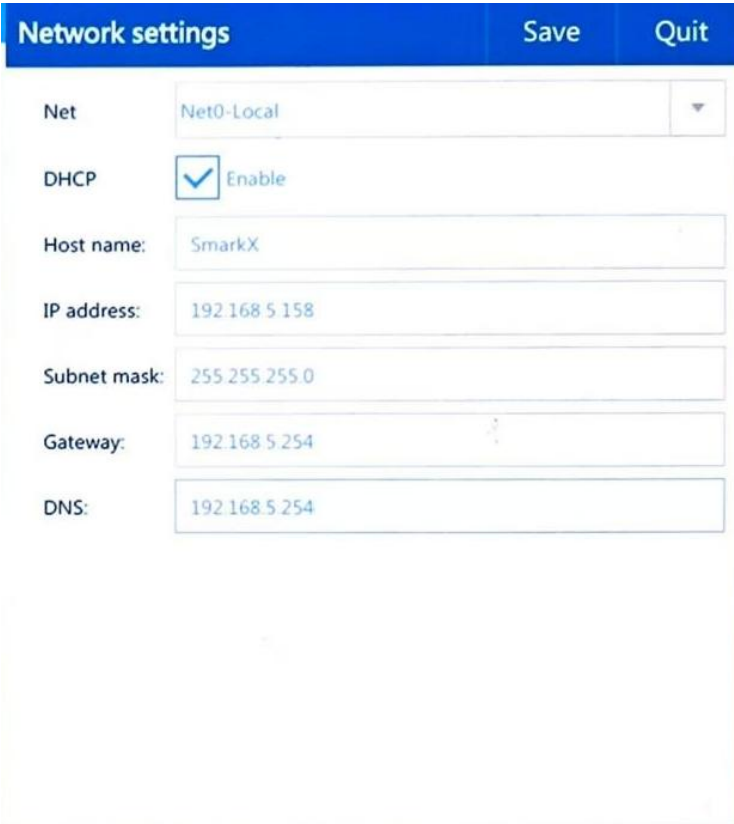

The screenshot shows a 'Network settings' window with a blue header bar containing 'Save' and 'Quit' buttons. The main area contains several input fields: 'Net' is a dropdown menu set to 'Net0-Local'; 'DHCP' is a checkbox that is checked and labeled 'Enable'; 'Host name:' is a text box containing 'SmarkX'; 'IP address:' is a text box containing '192.168.5.158'; 'Subnet mask:' is a text box containing '255.255.255.0'; 'Gateway:' is a text box containing '192.168.5.254'; and 'DNS:' is a text box containing '192.168.5.254'.

Figure 4-21

Host name: Set the motherboard name

IP address: Set up the motherboard IP address

Subnet mask, gateway, DNS without setting

Curve resolution: acting on the double-line font, the higher the resolution, the longer the marking time. For example, the curve

of the font is not round enough, the resolution can be reduced a little, but the marking time will be increased a little.

System font size: Set the system font size, and you can also set the size units.

Language: Set the system language type, and restart the system after switching the language

BC settings: used by internal developers.

Auto load file: automatically open the last file after starting up.

Automatic start: the system automatically performs the spray code after startup.

Screen saver: screen saver function is enabled, screen saver time, content, backlight brightness can be set, as shown in

Figure 4-22.

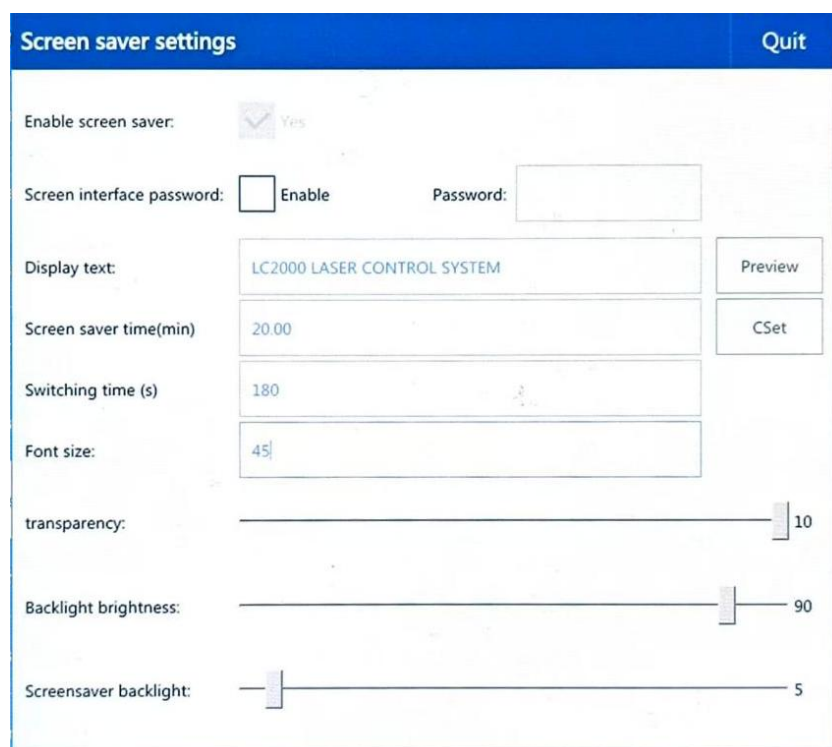
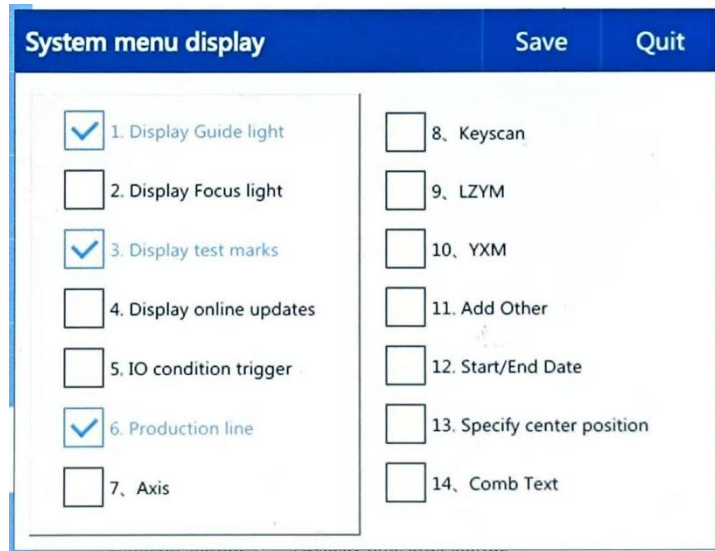

Figure 4-22

Other settings: automatically reset the serial number

Menu display: the tick function can be displayed in the status bar, as shown in Figure 4-23.



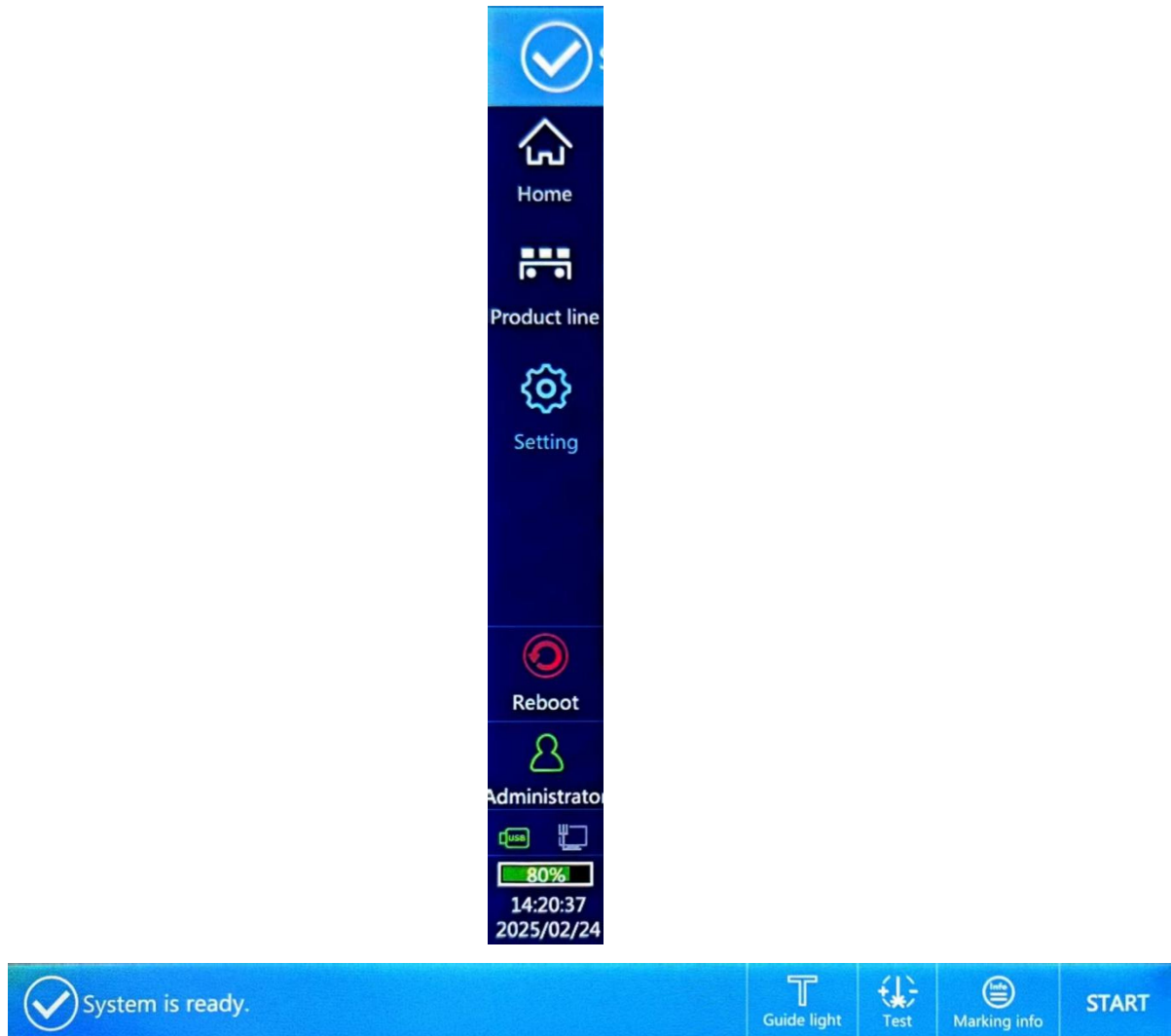

Figure 4-23

Keyboard char: Enter the keyboard character management interface to add symbols not found in the existing keyboard, as shown in Figure 4-24. Click Add symbols to enter the unicode coding interface. Each character has its specific unicode code, which can be found online or in word. Example: Add symbol ®, the corresponding unicode code is 00 AE, click 00 AE on the interface, as shown in Figure 4-25, click Add, add the symbol to the keyboard character management interface, as shown in

Figure 4-26, click the "more" button on the keyboard with the edited content to see the added characters, as shown in Figure 4-27.

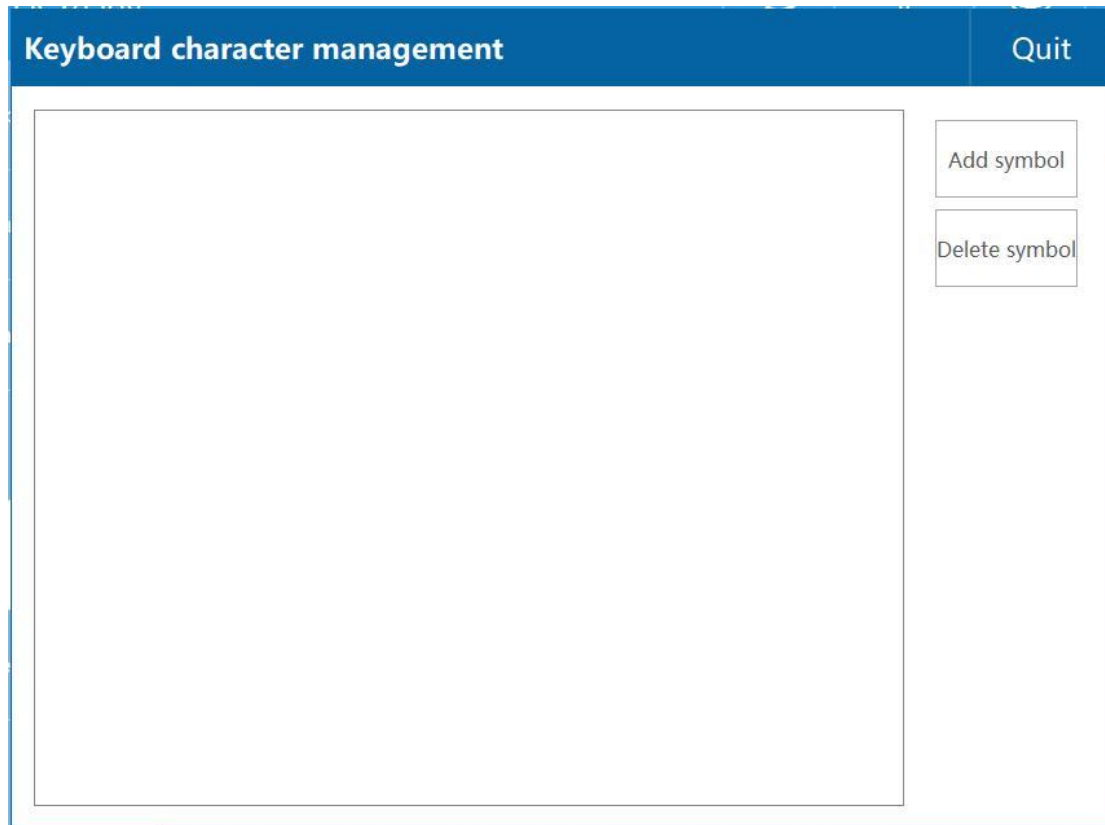

Figure 4-24

Add symbol

Please enter the character's Unicode encoding

	0	1	2	3
®	4	5	6	7
00AE	8	9	A	B
	C	D	E	F
	Delete			
Add		Quit		

Figure 4-25

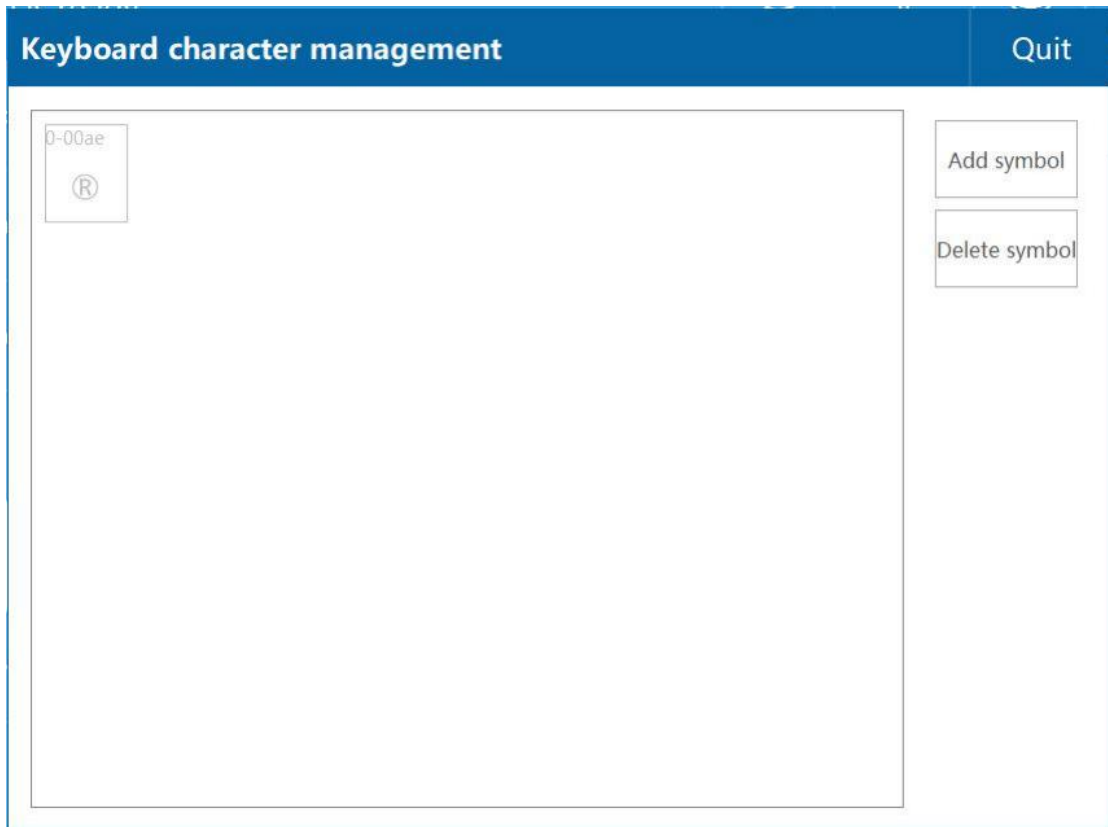

Figure 4-26

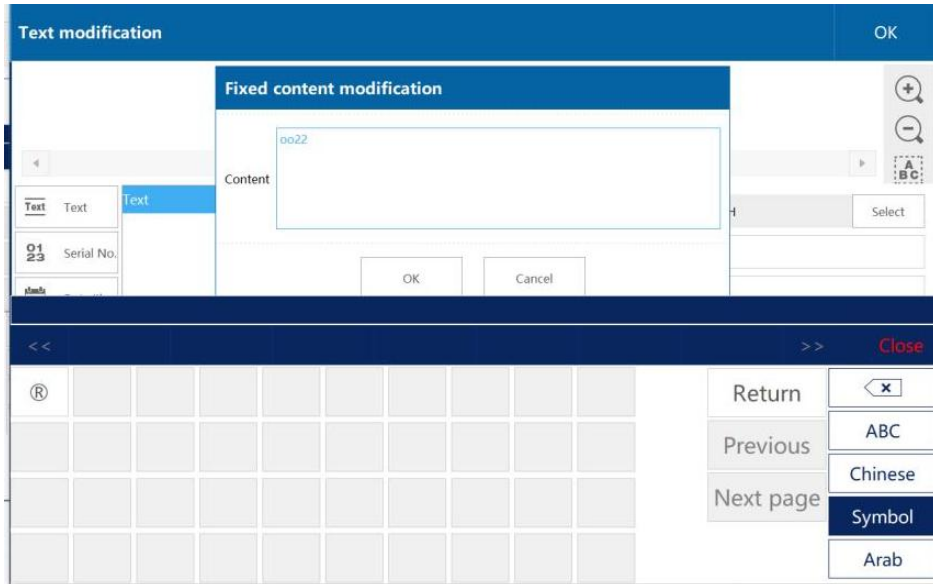

Figure 4-27

Input method: set the input method displayed in the keyboard. The keyboard can display up to 4 input methods at the same time, as shown in Figure 4-28.

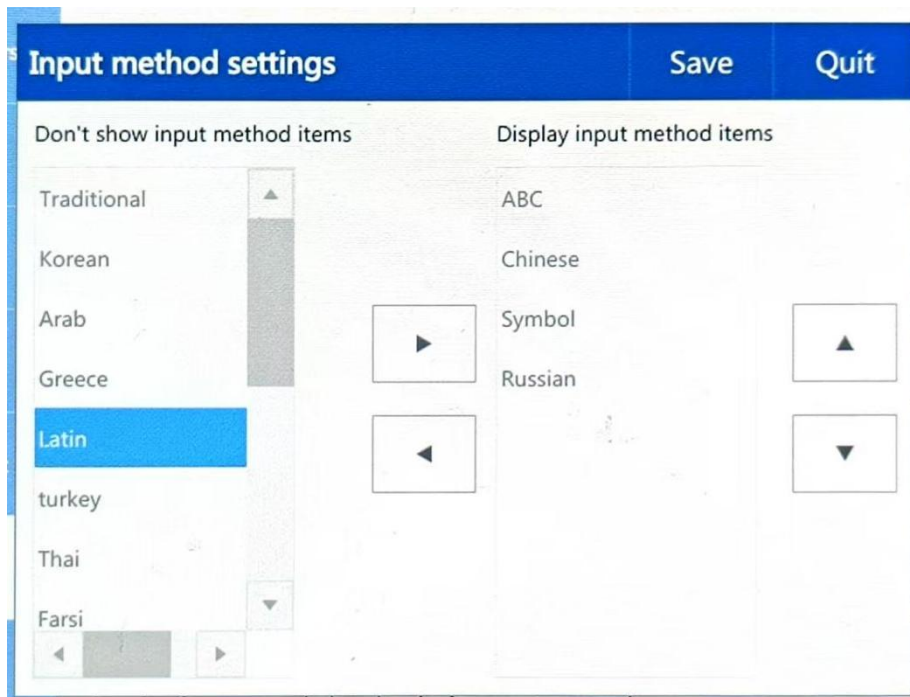
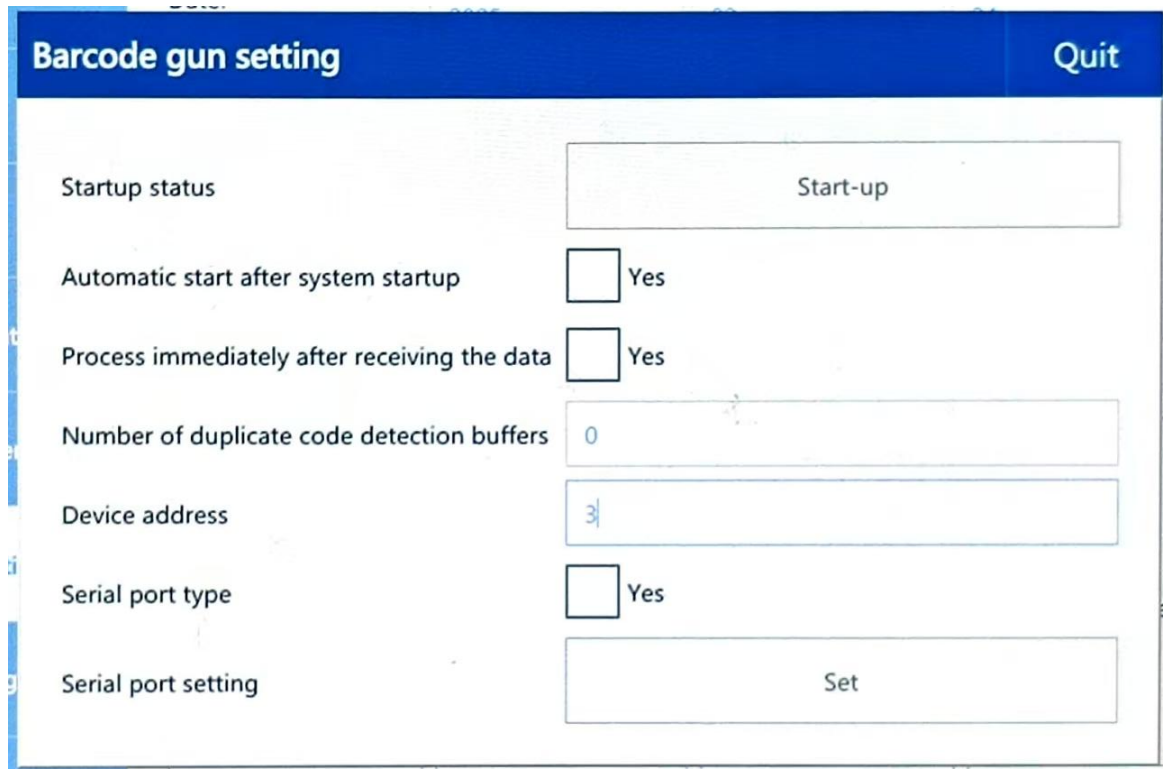
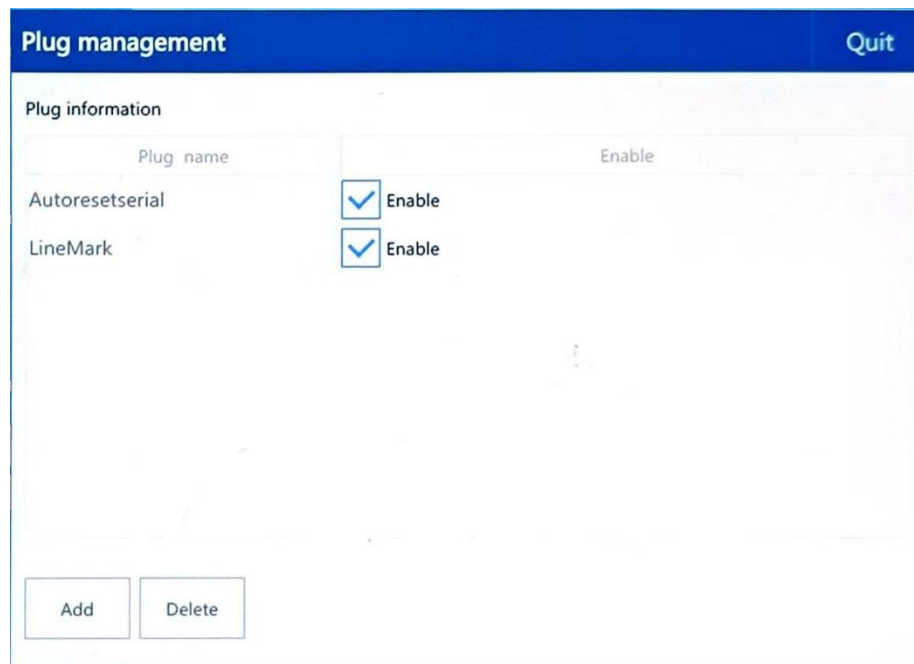

Figure 4-28

Bar code gun: Set the barcode gun input before using the scanning gun, set the start state to start, and automatically start the system after the start.



Plug management: the plug-ins can be deleted / added and enabled.



3.7. IO settings

Enable detection: (for developers to use)

IO output/input settings: As shown in Figure 4-29, there are a total of 5 IO signal outputs/inputs.

IO output function description:

Marking ready output: After entering the marking state, output a signal

Marking output: A signal will be output during each file marking process

Marking completed: After each file marking is completed, a signal will be output

Serial number end output: A signal will be output when the

serial number ends

Fault output: When a warning or error occurs in the system, a signal will be output

Manual output control: After setting, an enable control button will appear in the top bar, and users can manually control the output/disable signal.

Pre processing sensor detection: When marking is not initiated, if a sensor triggers it, it will output a signal

CTDa: Internal use of the system

Machine working state: It is in a conductive state before processing and in a non-conductive state during the marking process

Power saving management: Handheld device saves power control

Output status 0, 1, 2, 3, 4: can be manually controlled separately for output

Example: When it is necessary to mark the end output, the setting method is as follows:

1. OUT-1 is set as marking end output
2. (Note: IO output is low level) If the wiring object is a solid-state relay, the positive terminal of the relay should be connected to the 5V (PL19) output port of the interface board,

and the negative terminal should be connected to the 0_1 port.

3. Set the output signal width for marking completion

4. Click save and restart the system

(Specific wiring and usage instructions: Please contact after-sales personnel)

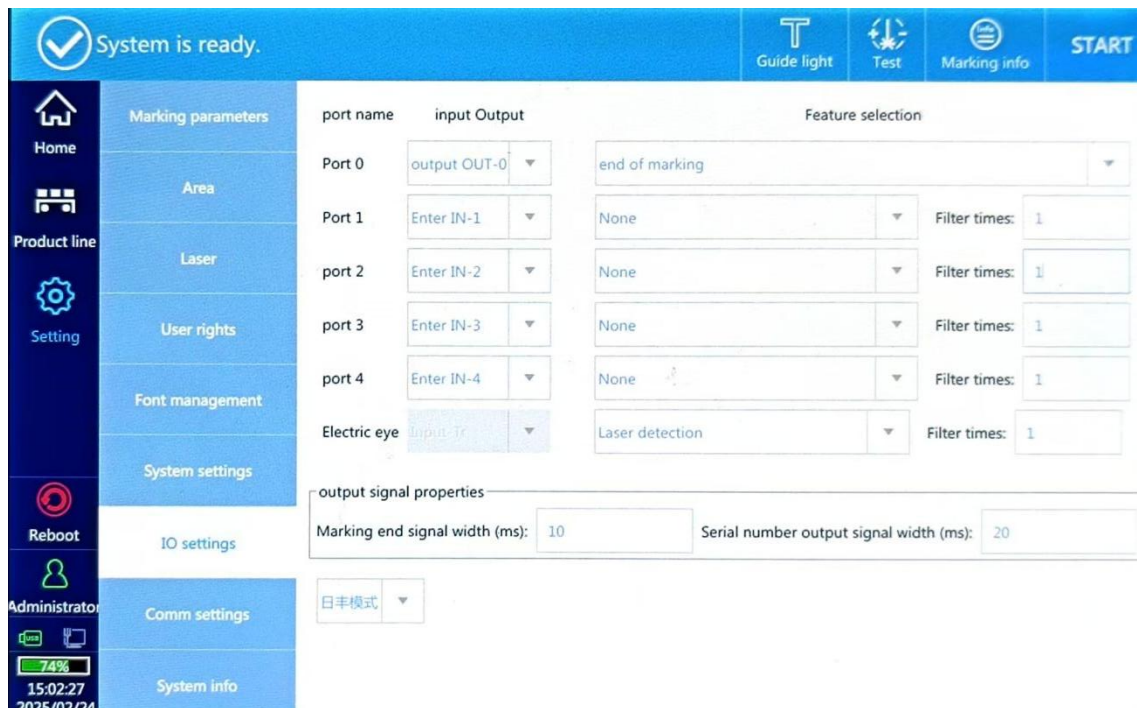

Figure 4-29

IO Input Function Description:

Reset serial number: Reset the serial number by controlling the input switch signal.

Start/Stop Processing: Control the start and stop of printing by inputting switch signals.

Interlocking detection: connected to external interlocking signals.

Chiller: Connected to external smoke exhaust machine and

chiller signal.

Press and hold to continue processing: Connect external button, press print, release to stop printing.

Conditional triggering processing: Open menu display/IO trigger, detect external IO status for conditional printing

Manual switching of serial number: When the serial number is triggered manually, use IO to increase the serial number.

Switching information 1, 2: Internal use of the system

Security door: If the security door is opened during the marking state, printing will stop. After closing the security door, it will enter the printing state

Signal information: Sending communication data information to the outside world

Starting motor: Starting motor control

CTst1, SSRreset: Internal use of the system

Electric eye: reserved connection port for vibrating mirror

3.8. Comm settings

If you need to use this function, please contact our staff.

3.9. System info

Display relevant information, updates, and registration information of the system, as shown in Figure 4-32.

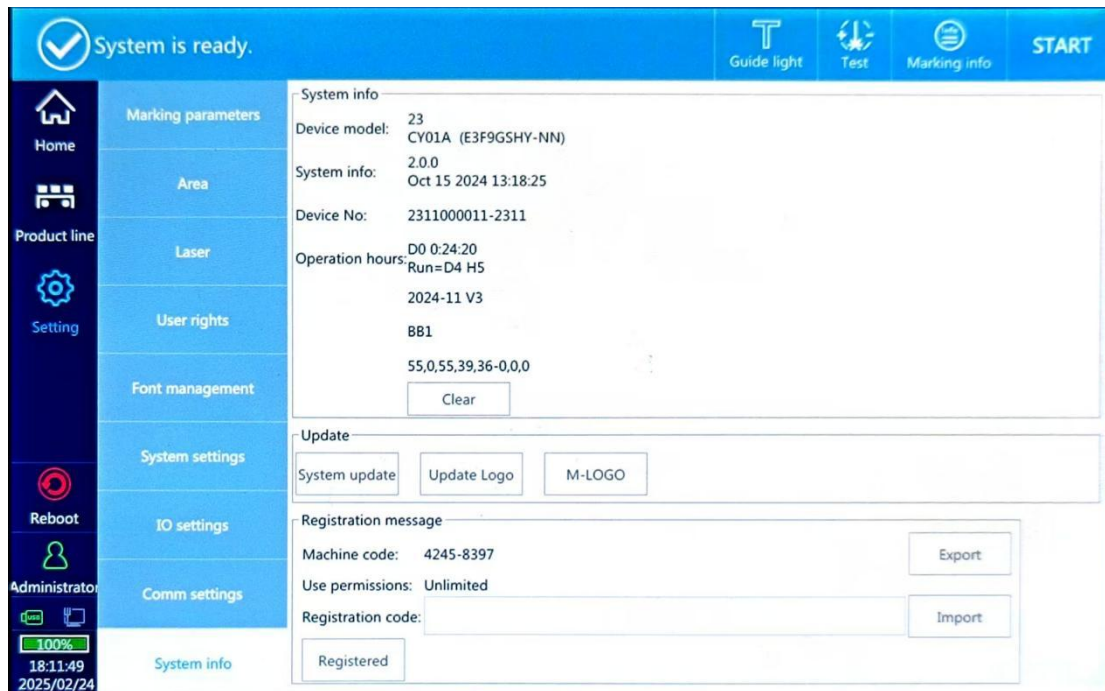

Figure 4-32

3.9.1. Update

The update includes system upgrade, changing the boot interface, and modifying the image in the upper left corner of the machine page.

The steps for system upgrade are as follows: (First, log in as an administrator)

1. Save the updated file to a USB drive and insert it into the USB drive
2. Click on system update, and a pop-up interface will appear as shown in Figure 4-33

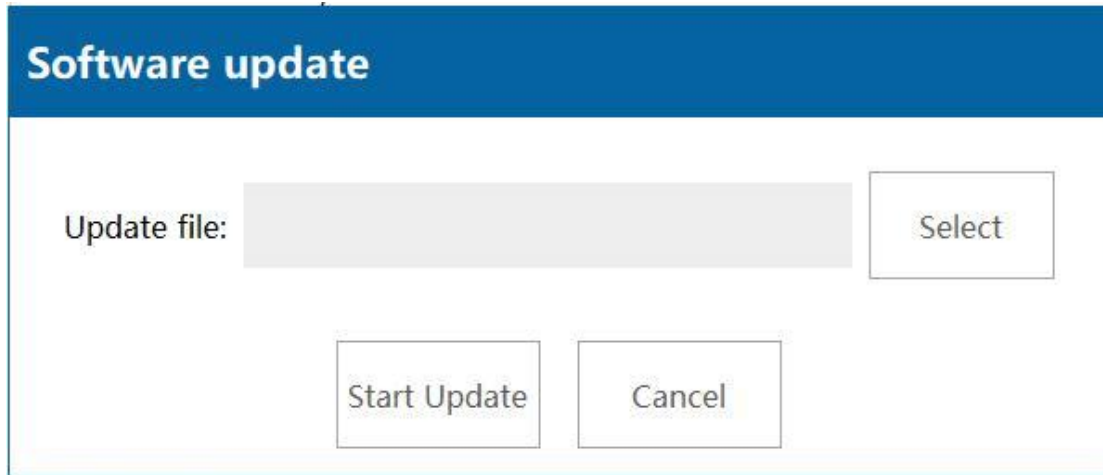

Figure 4-33

3. Click to select, and a pop-up interface will appear as shown in Figure 4-34

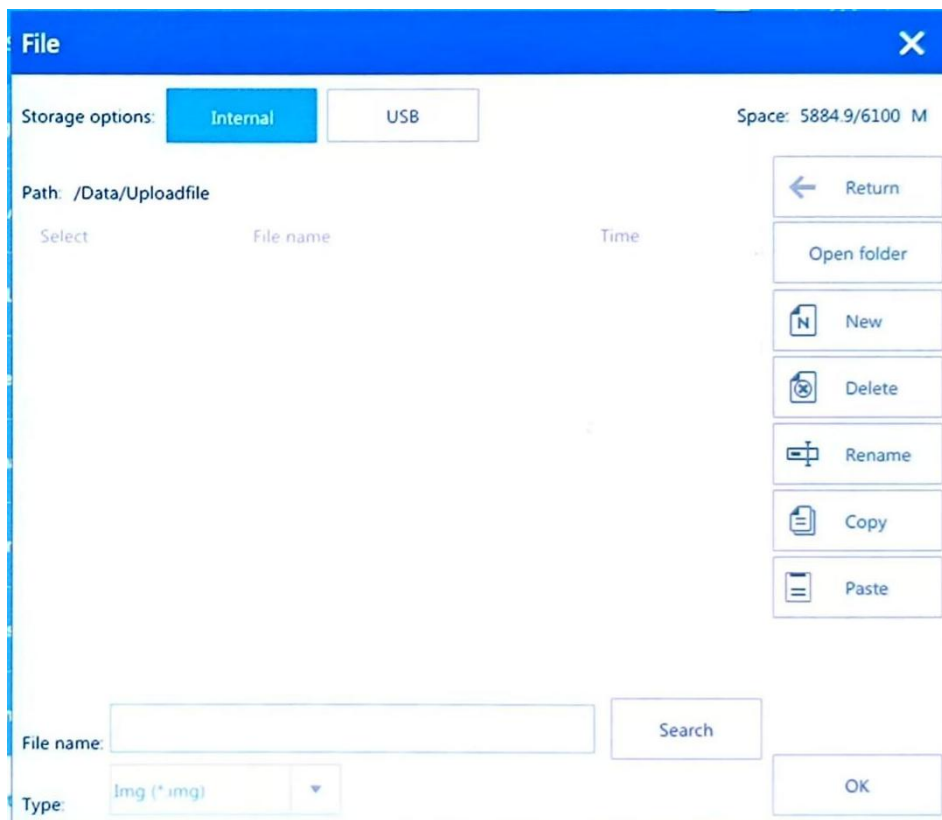

Figure 4-34

4. Click on USB, select the update file, click OK, and then click Start Update to complete the update

The steps to change the boot interface are as follows:

1. Startup image creation (format: bmp, Resolution: 1280 * 800, bits depth: 32)
2. Name the created image as logo, then save the image to a USB drive and insert it into the drive
3. Click to update logo, and a pop-up interface will appear, as shown in Figure 4-35.

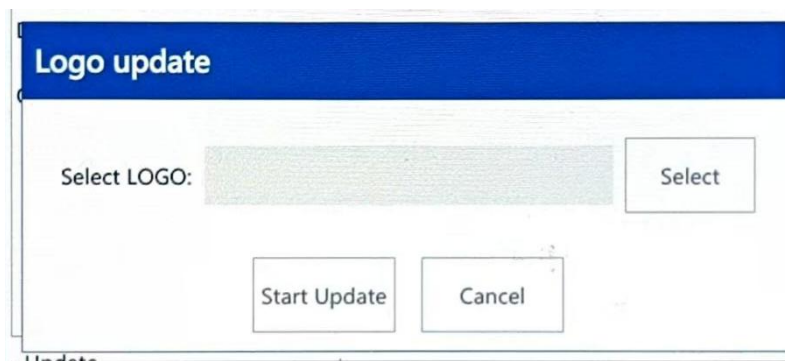

Figure 4-35

4. Click Select, click USB, select Update Files, click OK, click Start Update to complete the update

The steps to update the logo in the upper left corner of the page are as follows:

1. Image production (customizable logo image, image size is 25X16mm)
2. Save the created image to a USB drive and insert it into the drive
3. Click on M-LOGO, and a pop-up interface will appear, as shown in Figure 4-35

4. Click Select, click USB, select Update Files, click OK, click Start Update to complete the update.

3.9.2 Registered

Limit software usage time or days

The steps are as follows:

Step 1: Export the machine code to a USB drive. The steps are as follows:

1. Open the machine and log in to the system (password: 123)
2. Click on Setting ->System Info ->Export Machine Code
(complete the operation according to the system prompt)

Step 2: Open the registration software (the registration software is sent separately to the laser manufacturer)

Step 3: Enter the machine code. (Note: The machine code can be directly exported from the operation screen to the USB drive. Follow the on-screen prompts to complete the operation.)

Step 4: Set the key (the key is the key of the machine, be sure to remember it, and the next time the machine is registered, it must be used to register)

Step 5: Set the trial period or permanent use

Step 6: Generate a registration code and save it to a USB drive

Step 7: Register on the machine

1. Login user, password 123 (administrator)

2. Click on Settings ->System Infor, import the registration code (previously saved as a TXT document on the USB drive)
3. Click to Registered

4. Equipment parameters

Technical parameter table	
Laser	Fiber Laser Generator (Second Generation)
The output power	depends on the purchased model
Marking range	70x70mm, 100x100mm (optional)
Deflection mirror	High precision dual dimensional scanning system
Wave length	1064nm
focus lens	130mm
Marking speed	< 7000mm/s
master control	Integrated motherboard, 8-inch capacitor fully integrated screen
operating system	Linux System
Marking and engraving	Dot matrix and vector

type	all-in-one machine
line width	0.03mm
repeatability	0.01 mm
locate mode	Red light positioning and focusing
Number of engraved character lines	Any row within the effective marking range
PRINT SPEED	800 characters (related to material and printing content)
font	Standard character libraries for Chinese, English, numbers, traditional Chinese, etc
file format	BMP、 DXF、 PNG、 JPEG、 PLT
bar code	CODE 2-Of-5 Interleaved、 CODE39、 CODE128、 CODE126、 QR、 Codabar、 CODE93、 UPC-A、 UPC-E、 EAN-14、 ITF-14、 EAN128
power supply	110V/220V AC.lithium

	<p>battery(216wh)</p> <p>Lithium battery pack:</p> <p>20W/30W: 216Wh,</p> <p>50W: 333Wh</p>
<p>Overall Power Consumption</p>	<p>145 - 250W</p>
<p>Operating temperature of the whole machine</p>	<p>0 - 40°</p>
<p>The whole machine weight</p>	<p>20W/30W: 6-6.8KG, 50W: 8-8.8KG</p>

How to charge a handheld laser marking machine (battery version)

When your handheld laser marking machine prompts low battery, please use the power adapter provided by our company to charge it. And follow the following rules:

1. The product must be charged using our official designated charging equipment. We will not be responsible for any consequences caused by using non official designated charging equipment for charging.
2. Please place the machine on a ground without flammable or combustible materials when charging. Please be present

during product charging to prevent accidents.

3. Avoid continuous full load discharge, as the product battery may be in a high temperature state. Please wait for the machine to cool down to room temperature before proceeding.

How to clean a handheld laser marking machine?

Handheld laser marking machines have a wide range of applications, especially for small and medium-sized businesses and laser enthusiasts, so they may need to undergo simple cleaning from time to time. Please use dry non frosted gauze to wipe. If you want a deeper cleaning, we recommend using cleaning agents specifically designed for mobile phones and computer screens. Do not allow the product to come into contact with large amounts of conductive or corrosive liquids such as water!

5. Packaging content

Packaging box specifications: 20W/30W: 525 × 423 × 310 mm,

50W: 525 × 420 × 340mm

Packaging+machine weight: 20W/30W: 8-10KG, 50W:

10-12KG